

Reflections on S-parameter Quality

DesignCon IBIS Summit, Santa Clara, February 3, 2011

Solution: "MicroVias"

- 6PBoard
 - Materials
 - "copper", RRes=1, Rough=0.01
 - "IdealMetal"
 - "prepreg", DK=4.7, LT=(
 - "vacuum"
 - "FR4", DK=4.2, LT=0.02
 - StackUp: LU=[mil], NL=15, T
 - TopTransitions
 - CircuitData: LU=[mil]
 - Multiport: 2 inputs, 2
 - LatticeBox
 - Geometry
 - GeoComposite: "
 - TLines
 - Inputs
 - ThickMetal
 - CollapsedMetal
 - BottomTransition

Yuriy Shlepnev

shlepnev@simberian.com

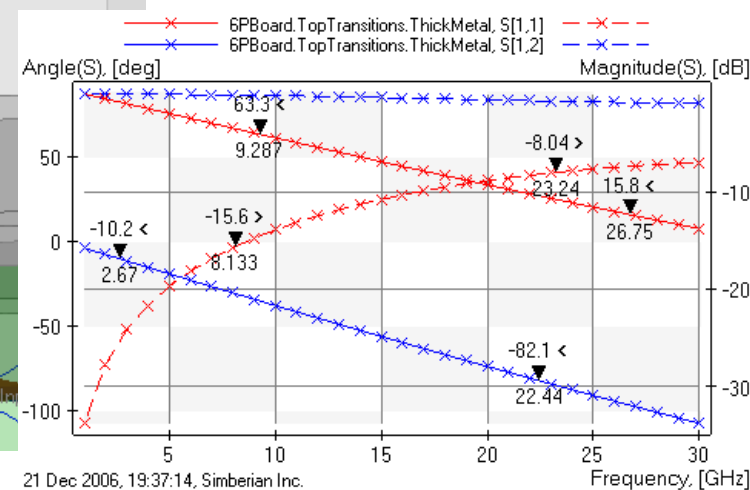
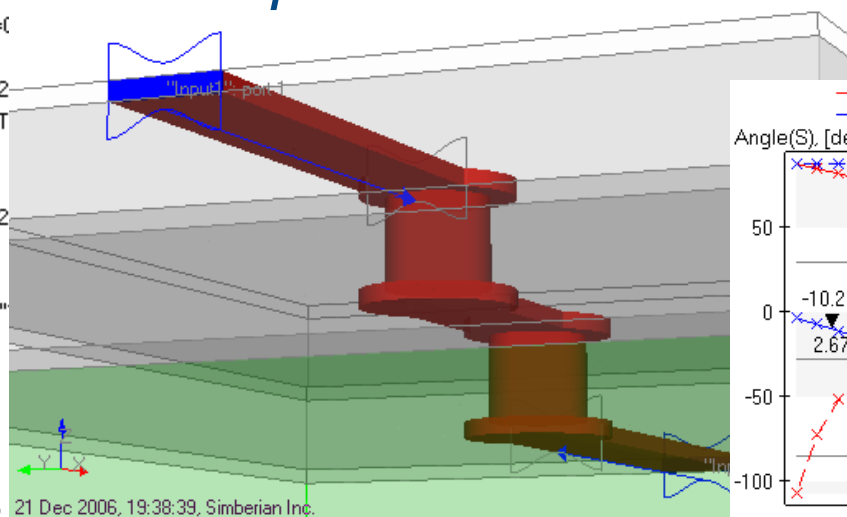

Outline

- Introduction
- Quality of S-parameter models
- Rational macro-models of S-parameters and final quality metric
- Examples
- Conclusion
- Contacts and resources

Introduction

- S-parameter models are becoming ubiquitous in design of multi-gigabit interconnects
 - Connectors, cables, PCBs, packages, backplanes, ... ,any LTI-system in general can be characterized with S-parameters from DC to daylight
- Electromagnetic analysis or measurements are used to build S-parameter Touchstone models
- Very often such models have quality issues:
 - Reciprocity violations
 - Passivity and causality violations
 - Common sense violations
- **And produce different time-domain and even frequency-domain responses in different solvers!**

What are the major problems?

- Model **bandwidth deficiency**
 - S-parameter models are band-limited due to limited capabilities of solvers and measurement equipment
 - Model should include DC point or allow extrapolation, and high frequencies defined by the signal spectrum
- Model **discreteness**
 - S-parameter models are matrix elements at a set of frequencies
 - Interpolation or approximation of tabulated matrix elements may be necessary both for time and frequency domain analyses
- Model **distortions** due to
 - Measurement or simulation artifacts
 - Passivity violations and local “enforcements”
 - Causality violations and “enforcements”
- **Human mistakes of model developers and users in general**

Pristine models of interconnects

- ❑ Must have sufficient bandwidth matching signal spectrum
- ❑ Must be appropriately sampled to resolve all resonances
- ❑ Must be reciprocal (linear reciprocal materials used in PCBs)

$$S_{i,j} = S_{j,i} \text{ or } S = S^t$$

- ❑ Must be passive (do not generate energy)

$$P_{in} = \bar{a}^* \cdot [U - S^* S] \cdot \bar{a} \geq 0 \quad \Rightarrow \quad \text{eigenvals}[S^* \cdot S] \leq 1 \quad \text{from DC to infinity!}$$

- ❑ Have causal step or pulse response (response only after the excitation)

$$S_{i,j}(t) = 0, \quad t < T_{ij}$$

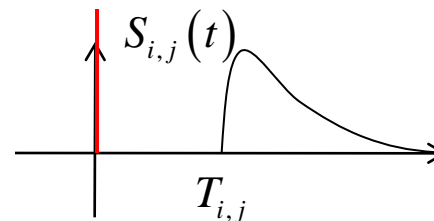

What if models are not pristine?

- ❑ Reciprocity, passivity and causality metrics was recently introduced for the model pre-qualification at DesignCon 2010 IBIS summit (references at the end)
- ❑ **Models with low metrics must be discarded!**
- ❑ Models that pass the quality metrics may still be not usable or mishandled by a system simulator
- ❑ **The main reasons are band-limitedness, discreteness and brut force model fixing**

Computation of system response requires frequency-continuous models

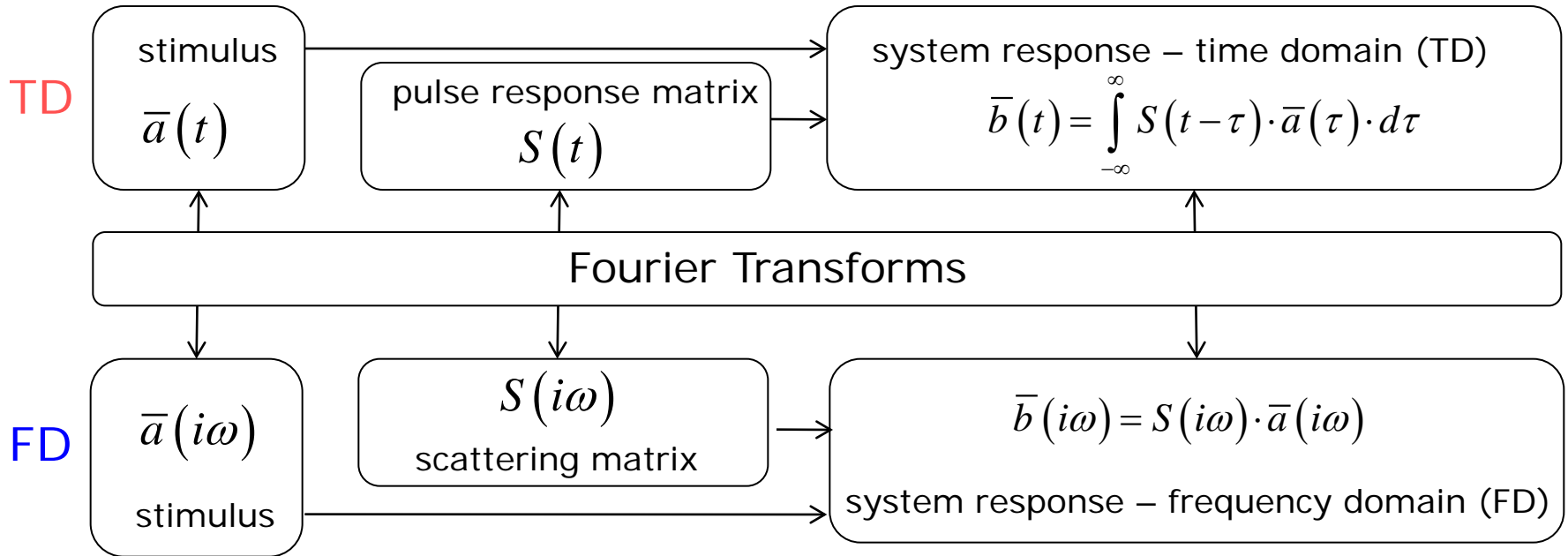

$$S(t) = \frac{1}{2\pi} \int_{-\infty}^{\infty} S(i\omega) \cdot e^{i\omega t} \cdot d\omega, \quad S(t) \in \mathbb{R}^{N \times N} \quad \longleftrightarrow \quad S(i\omega) = \int_{-\infty}^{\infty} S(t) \cdot e^{-i\omega t} \cdot dt, \quad S(i\omega) \in \mathbb{C}^{N \times N}$$

For TD analysis we can either use Discrete Fourier Transforms (DFT) and convolution or approximate discrete S-parameters with frequency-continuous causal functions with analytical pulse response

Rational approximation of S-parameters is such frequency-continuous model

$$\bar{b} = S \cdot \bar{a}, \quad S_{i,j} = \frac{b_i}{a_j} \Big|_{a_k=0, k \neq j} \Rightarrow S_{i,j}(i\omega) = \left[d_{ij} + \sum_{n=1}^{N_{ij}} \left(\frac{r_{ij,n}}{i\omega - p_{ij,n}} + \frac{r_{ij,n}^*}{i\omega - p_{ij,n}^*} \right) \right] \cdot e^{-s \cdot T_{ij}}$$

$s = i\omega$, d_{ij} – values at ∞ , N_{ij} – number of poles,
 $r_{ij,n}$ – residues, $p_{ij,n}$ – poles (real or complex), T_{ij} – optional delay

Continuous functions of frequency defined from DC to infinity

- Pulse response is analytical, real and delay-causal:

$$S_{i,j}(t) = 0, \quad t < T_{ij}$$

$$S_{i,j}(t) = d_{ij} \delta(t - T_{ij}) + \sum_{n=1}^{N_{ij}} \left[r_{ij,n} \cdot \exp(p_{ij,n} \cdot (t - T_{ij})) + r_{ij,n}^* \cdot \exp(p_{ij,n}^* \cdot (t - T_{ij})) \right], \quad t \geq T_{ij}$$

- Stable $\text{Re}(p_{ij,n}) < 0$

- Passive if $\text{eigenvals} [S(\omega) \cdot S^*(\omega)] \leq 1 \quad \forall \omega, \text{ from } 0 \text{ to } \infty$

- Reciprocal if $S_{i,j}(\omega) = S_{j,i}(\omega)$

May require enforcement

Bandwidth and sampling for rational approximation

- If no DC point, the lowest frequency in the sweep should be

- Below the transition to skin-effect (1-50 MHz for PCB applications)
- Below the first possible resonance in the system (important for cables, L is physical length)

$$L < \frac{\lambda}{4} = \frac{c}{4f_l \cdot \sqrt{\epsilon_{eff}}} \Rightarrow f_l < \frac{c}{4L \cdot \sqrt{\epsilon_{eff}}}$$

- The highest frequency in the sweep must be defined by the required resolution in time-domain or by spectrum of the signal (by rise time or data rate)

$$f_h > \frac{1}{2t_r}$$

- The sampling is very important for DFT and convolution-based algorithms, but not so for algorithms based on fitting

- There must be 4-5 frequency point per each resonance
- The electrical length of a system should not change more than quarter of wave-length between two consecutive points

$$df < \frac{c}{4L \cdot \sqrt{\epsilon_{eff}}}$$

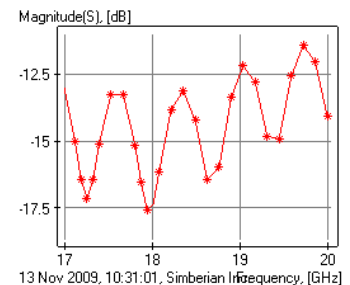

Rational approximation can be used for

- Compute time-domain response of a channel with a fast recursive convolution algorithm (exact solution for PWL signals)
- Improve quality of tabulated Touchstone models
 - Fix minor passivity and causality violations
 - Interpolate and extrapolate with guaranteed passivity
- Produce broad-band SPICE macro-models
 - Smaller model size, stable analysis
 - Consistent frequency and time domain analyses in any solver
- Measure the original model quality with the Root Mean Square Error (RMSE) of the rational approximation:

$$Q = 100 \cdot \max(1 - RMSE, 0) \% \quad RMSE = \max_{i,j} \left[\sqrt{\frac{1}{N} \sum_{n=1}^N |S_{ij}(n) - S_{ij}(\omega_n)|^2} \right]$$

So, how to avoid bad S-parameters?

- Use reciprocity and passivity metrics for preliminary analysis
 - RQM and PQM metrics should be > 80%
- Use the rational model quality metric as the final measure
 - QM should be > 90%
- **Otherwise discard the model**
 - The main reason is we do not know what it originally was and should be – no information

Example 1: Network with one real pole – shunt capacitor sampled up to 50 GHz

- 13 pF capacitance shunt to the ground

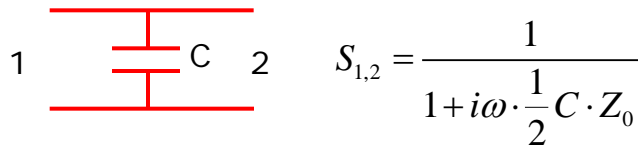

real pole at 489.707 MHz can be identified with just 5 frequency samples

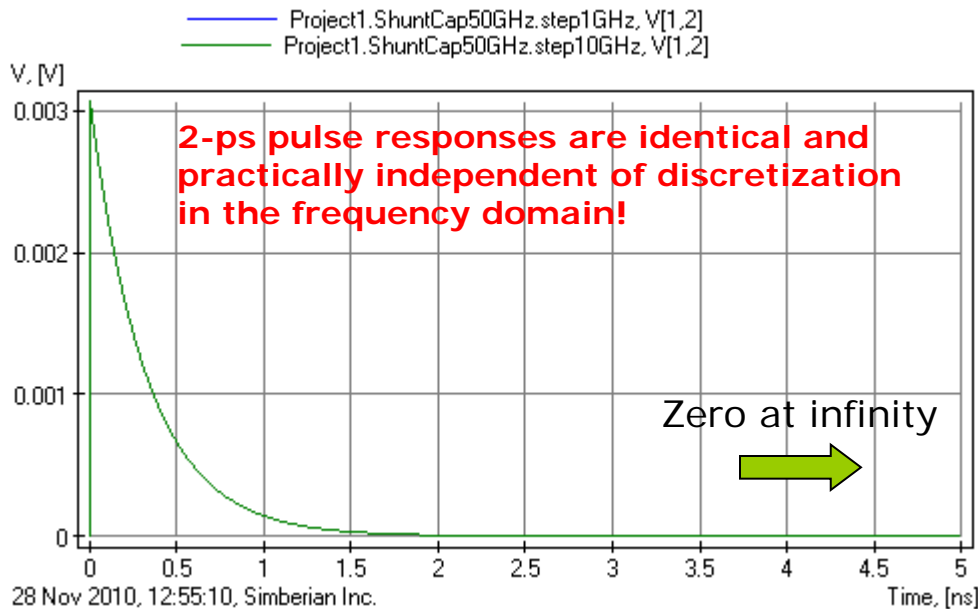

No artifacts!

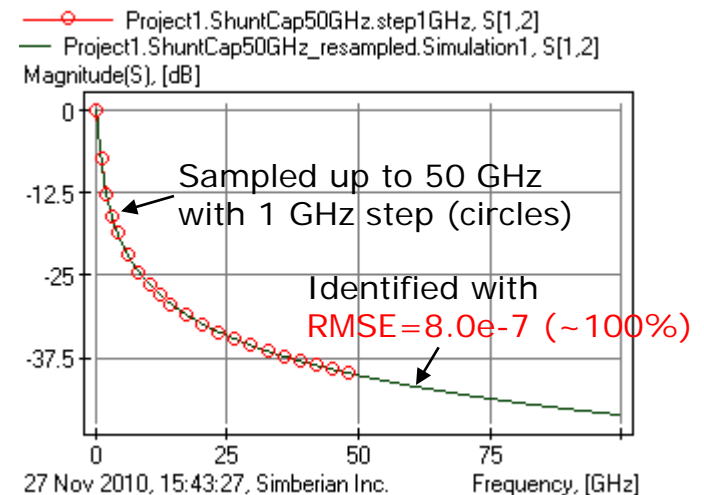
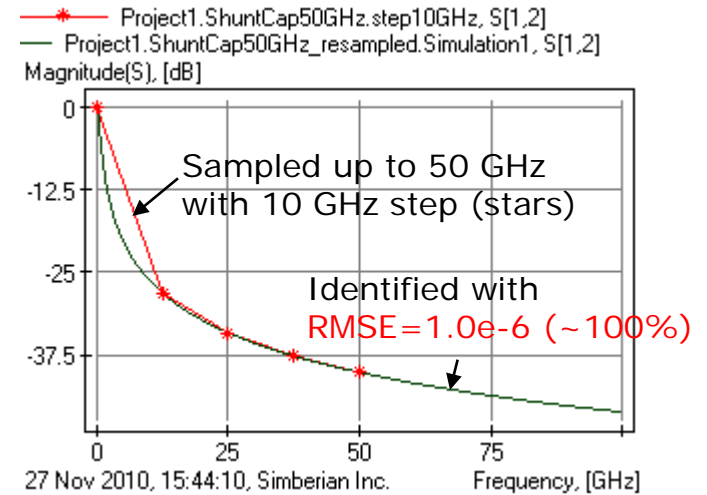

Example 1: Network with one real pole – shunt capacitor sampled up to 5 GHz

- 13 pF capacitance shunt to the ground

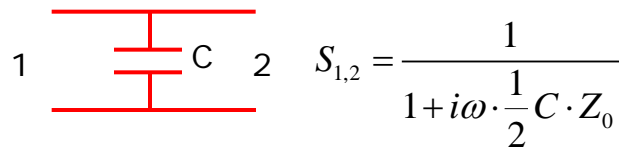

real pole at 489.707 MHz can be identified with just 5 frequency samples

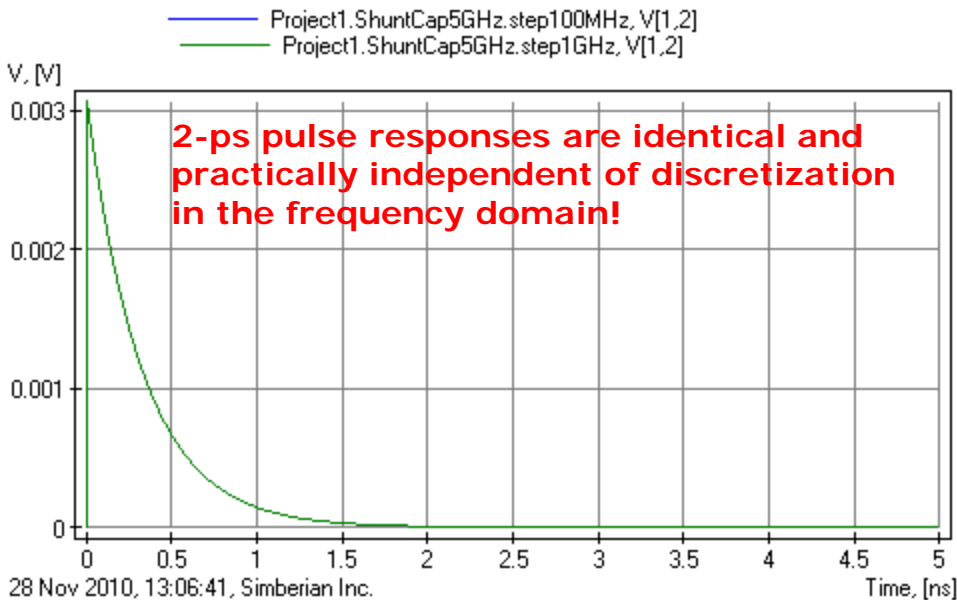

Still no artifacts!

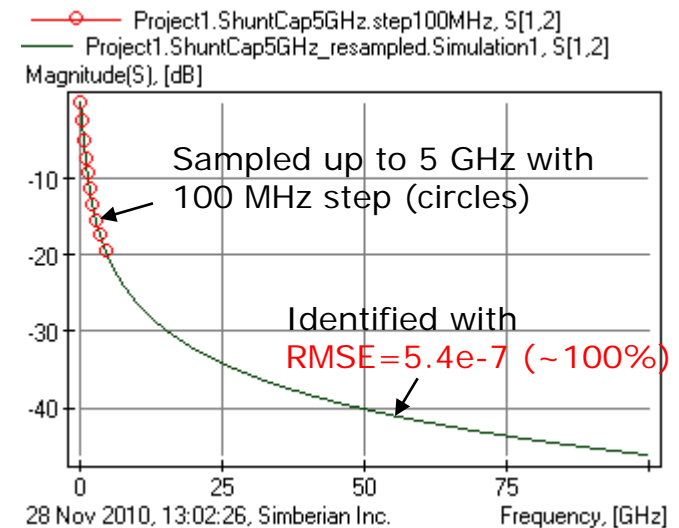
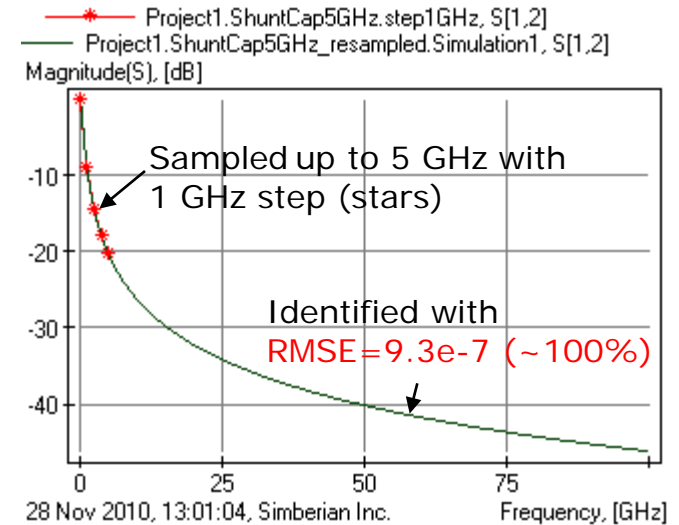

Example 2: Network with two complex poles

– shunt RLC circuit sampled up to 50 GHz

- Shunt tank: $C=13$ pF, $L=50$ pH, $R=1$ K

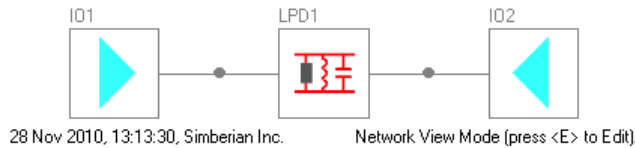

resonance at 6.24 GHz can be identified with 5 frequency samples

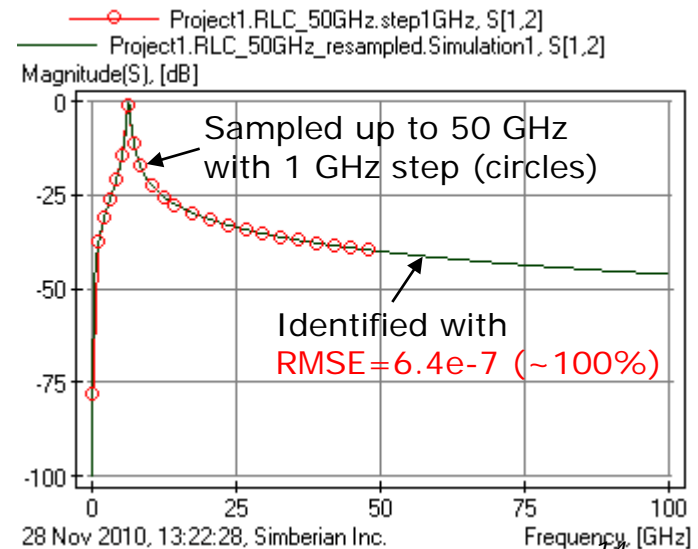
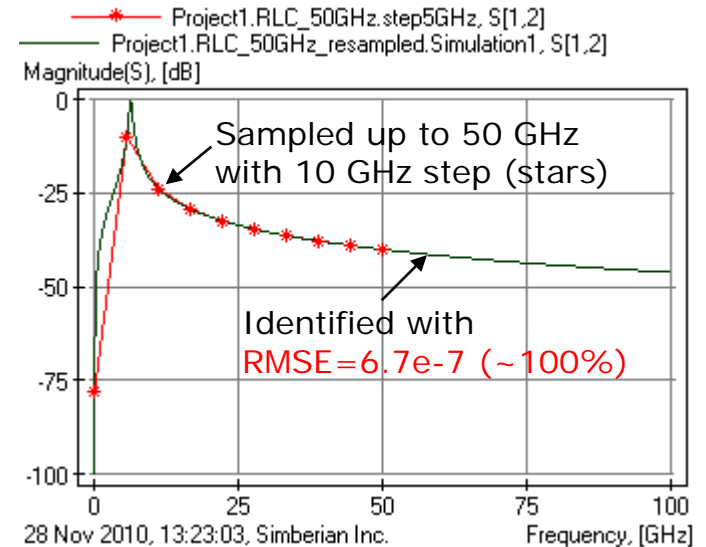
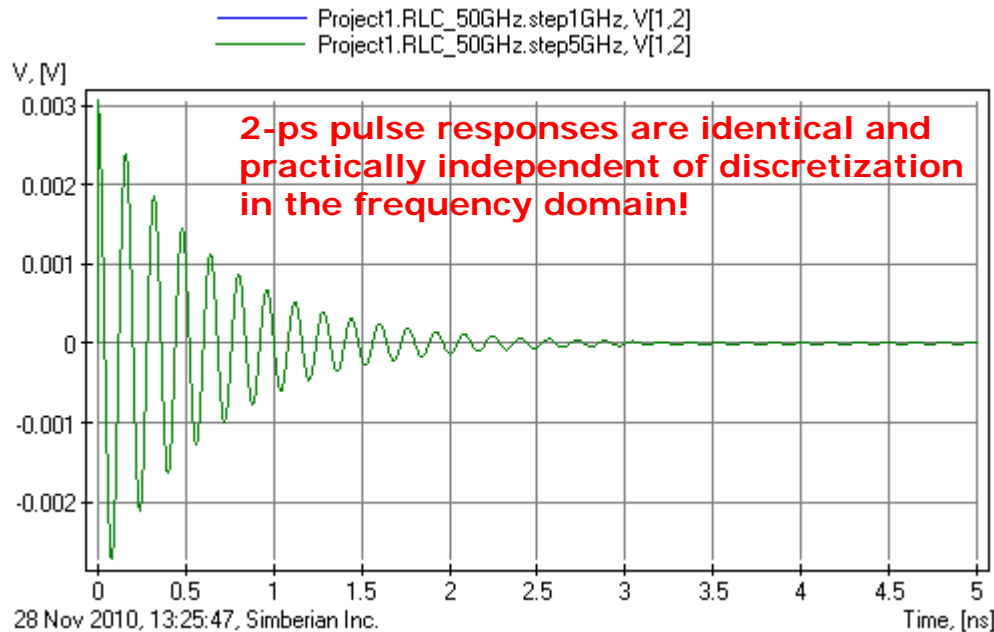

Example 2: Network with two complex poles

– shunt RLC circuit sampled up to 5 GHz

- Shunt tank: $C=13$ pF, $L=50$ pH, $R=1$ K

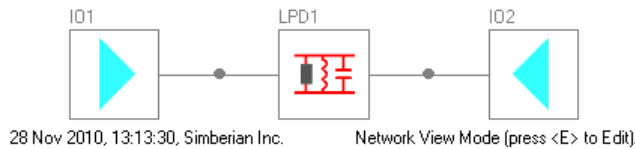

resonance at 6.24 GHz can be identified with 5 frequency samples

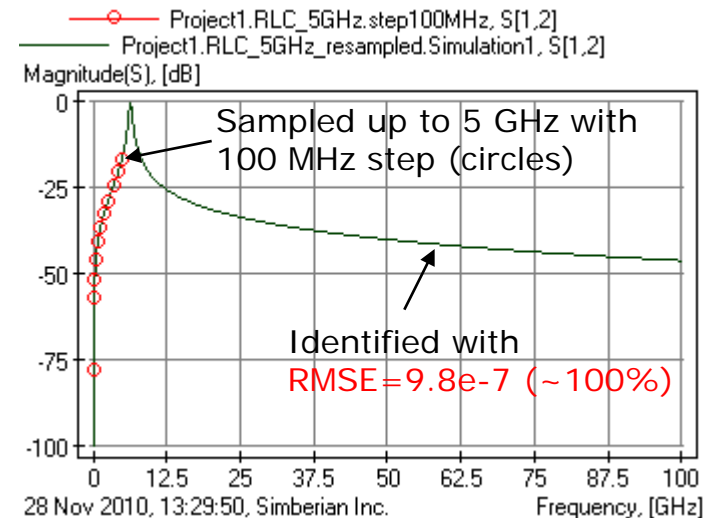
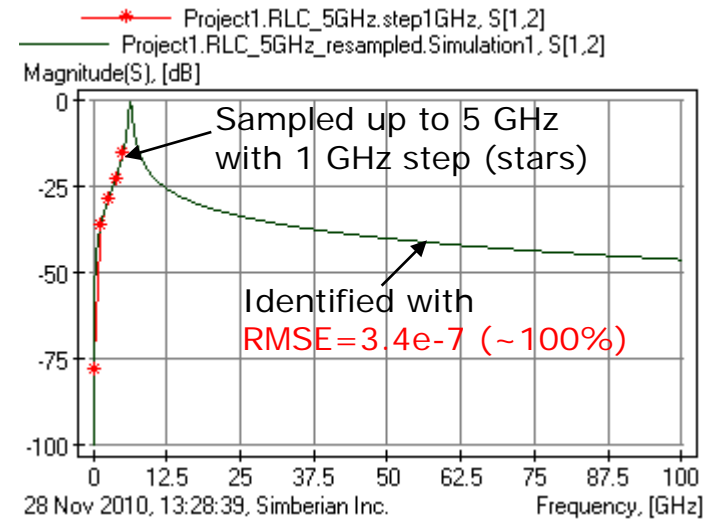
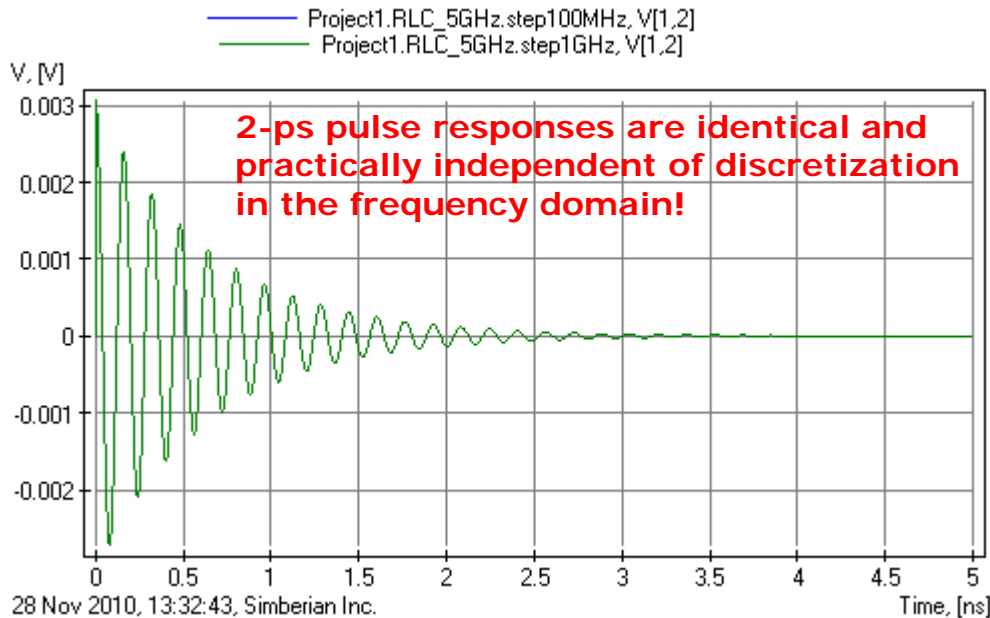

Example 3: Network with infinite number of poles – segment of ideal transmission line

- T-line segment: $Z_0=50$ Ohm, $T_d=1$ ns
50 Ohm termination
- $|S_{11}|$ is exactly 0 from DC to infinity
- $|S_{12}|$ is exactly 1 from DC to infinity
- Phase is growing linearly
- Group Delay is exactly 1 ns from DC to infinity
- **Such network is obviously non-physical**
- We will try to sample and approximate $|S_{21}|$ over some frequency band and compare the step responses

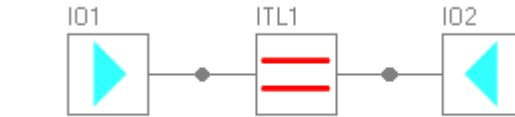

29 Nov 2010, 12:35:51, Simberian Inc.

Exact response to 100 ps delayed step with 20 ps rise time (10-90%)

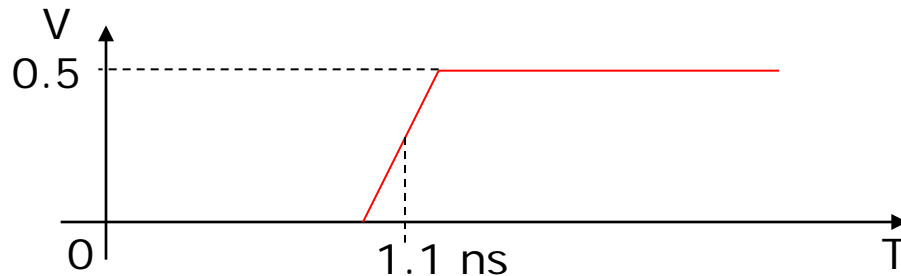

Example 3: Segment of ideal transmission line sampled up to 25 GHz

- Sampled with adaptive frequency sweep from 1 MHz to 25 GHz (628 samples) – stars and pluses on the left graph
- Approximated with rational macro-model with 100 poles (RMSE=0.0037, Q=99.63) – solid lines on left graph and TD graph

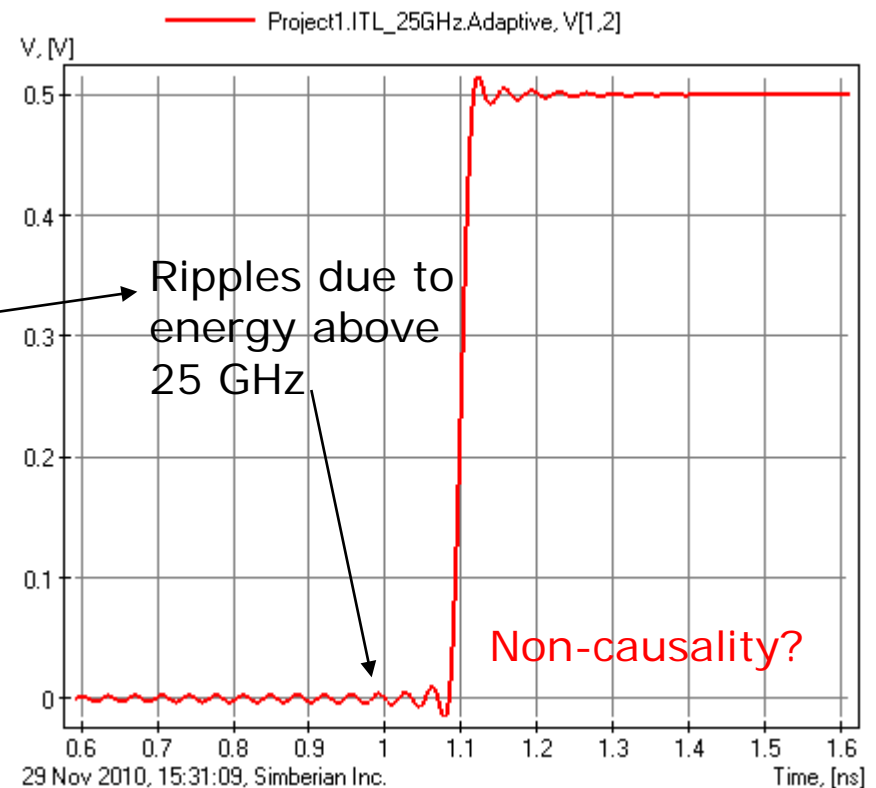
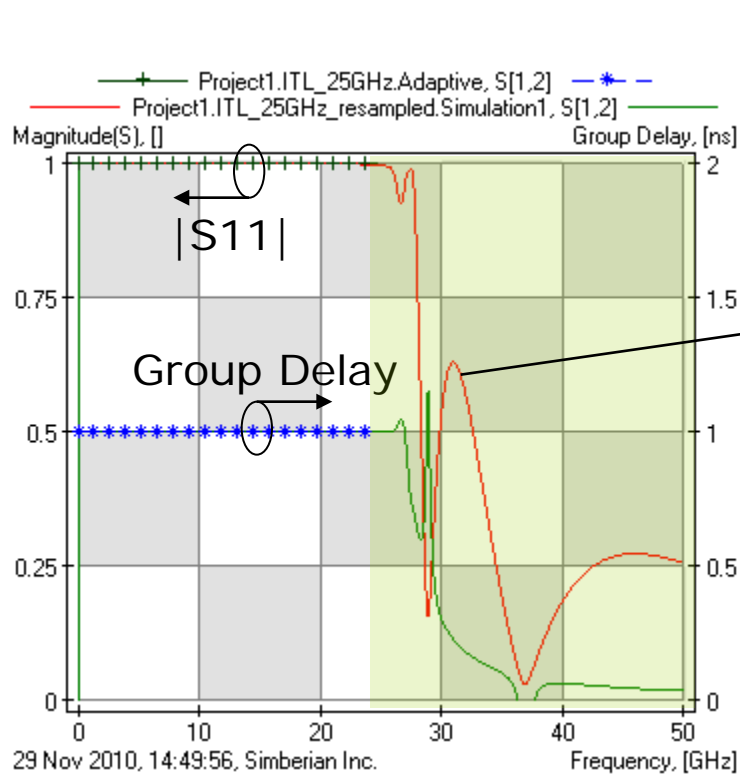

Example 3: Segment of ideal transmission line sampled up to 50 GHz

- Sampled with adaptive sweep from 1 MHz to 50 GHz (1278 samples) – stars and pluses on the left graph
- Approximated with rational macro-model with 190 poles (**RMSE=0.0045, Q=99.55**) – solid lines on left graph and TD graph

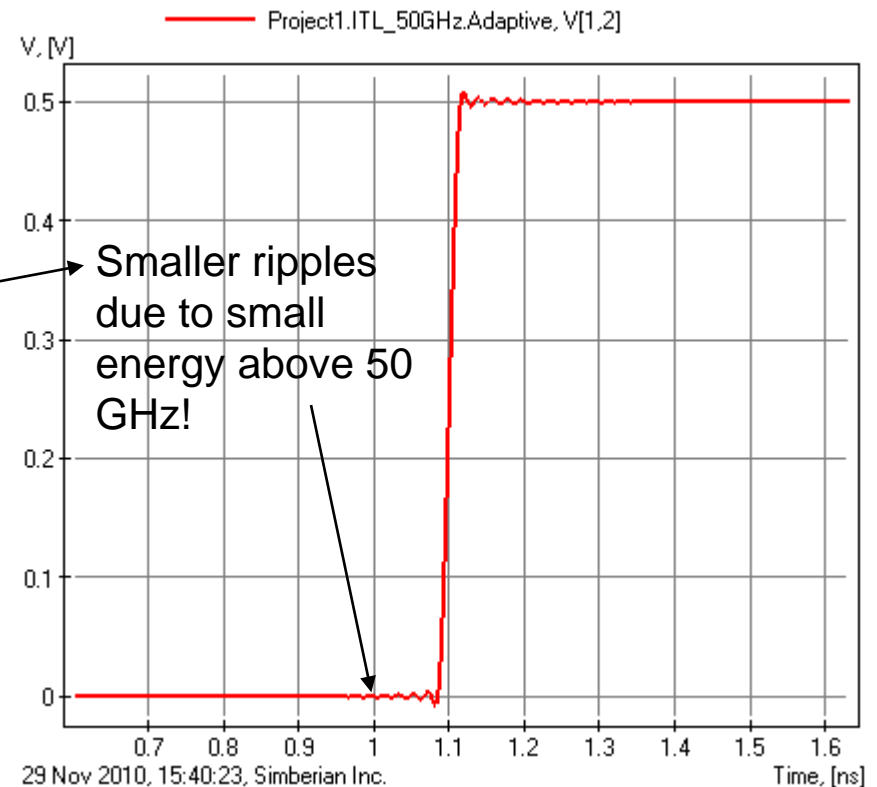
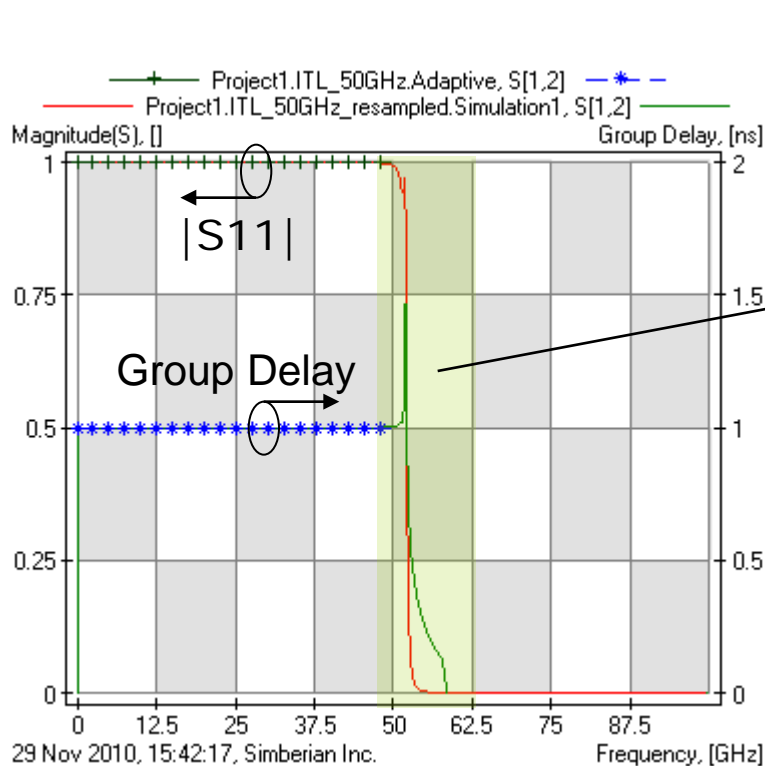

Spectrum of ramped step stimulus still exceeds the bandwidth of the model!

Example 3: Segment of ideal transmission line sampled up to 50 GHz

Gaussian step stimulus with 20 ps rise time (10-90%)
Spectrum: -20 dB at 44 GHz and -40 dB at 62 GHz

Gaussian Step (ideal step filtered with the Gaussian filter)

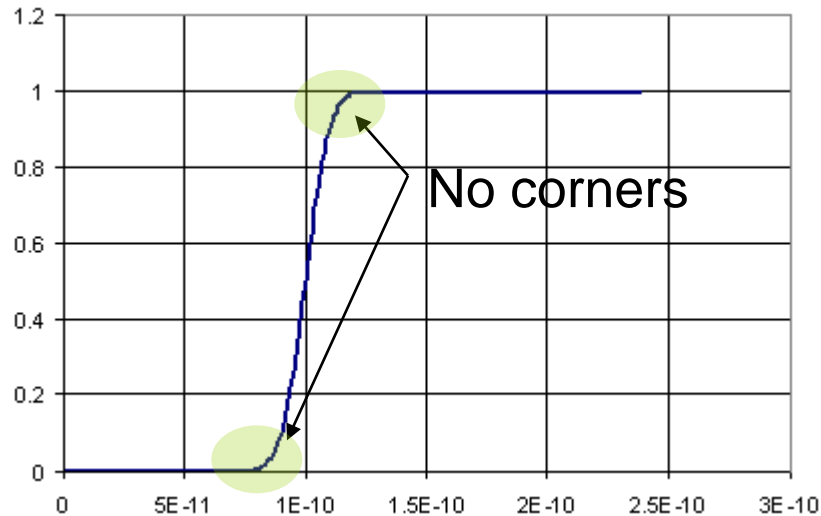

Rational Macro-Model Response

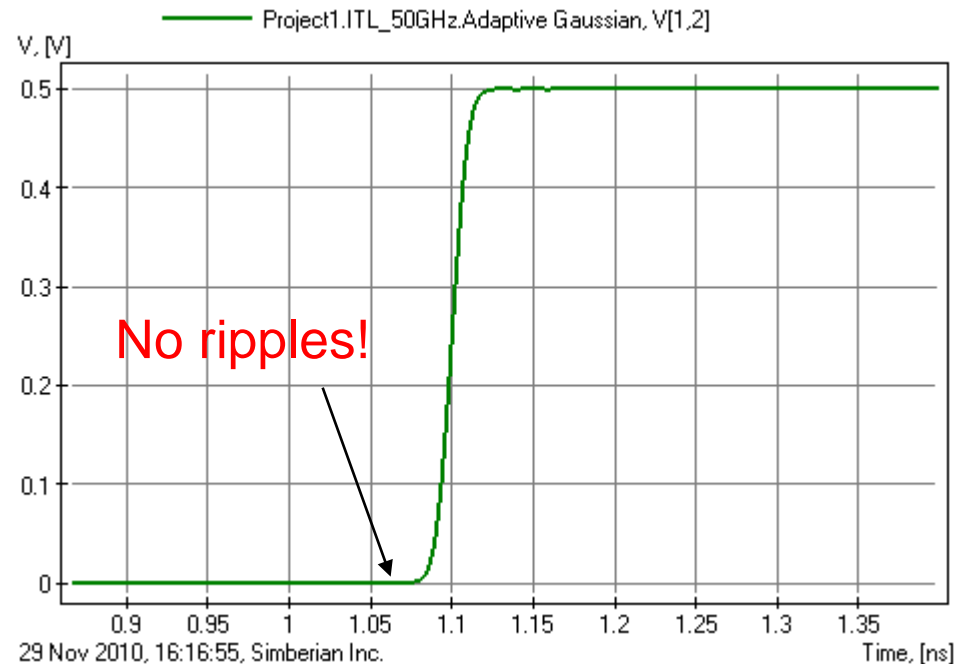

No ripples in the computed time-domain response – model bandwidth matches the excitation spectrum!

Practical examples from panel TP-T3

Acceptable (see next slides)

Discard

Acceptable

The screenshot shows the Simbeor Touchstone Analyzer interface. On the left, a file list table displays the following data:

File name	Quality	Passivity	Reciprocity	Causality
10 in Link MM.s4p	94.8	100	99.8	97.1
C:\emForce\Examples\AppNotes\DesignCon2011\AvoidButchering...				
Bill.s4p	42.6	100	98	94.4
C:\emForce\Examples\AppNotes\DesignCon2011\AvoidButchering...				
Charlie.s4p	59.3	100	97.6	0
C:\emForce\Examples\AppNotes\DesignCon2011\AvoidButchering...				
Fred.s4p	90.3	100	100	100
C:\emForce\Examples\AppNotes\DesignCon2011\AvoidButchering...				
George.s4p	73.6	100	94.8	0
C:\emForce\Examples\AppNotes\DesignCon2011\AvoidButchering...				
channel_model_08-655.s4p	99.4	100	99.8	83.2

On the right, a plot shows Magnitude(S) [dB] versus Frequency [GHz]. The plot contains several curves in different colors (red, green, blue, black) showing the magnitude response of various components. The x-axis ranges from 0 to 40 GHz, and the y-axis ranges from 0 to -110 dB. A sharp resonance dip is visible around 20 GHz.

Common sense analysis of system response may be also useful

Acceptable Measured Model Example: U-shaped 10-in differential link

- Model supplied by Peter Pupalaikis (LeCroy), 2001 points from 0 to 40 GHz
- 4 by 4 S-matrix is approximated with rational macro-model with 300-400 poles per element, max **RMSE=0.055**, **Q=94.5%**

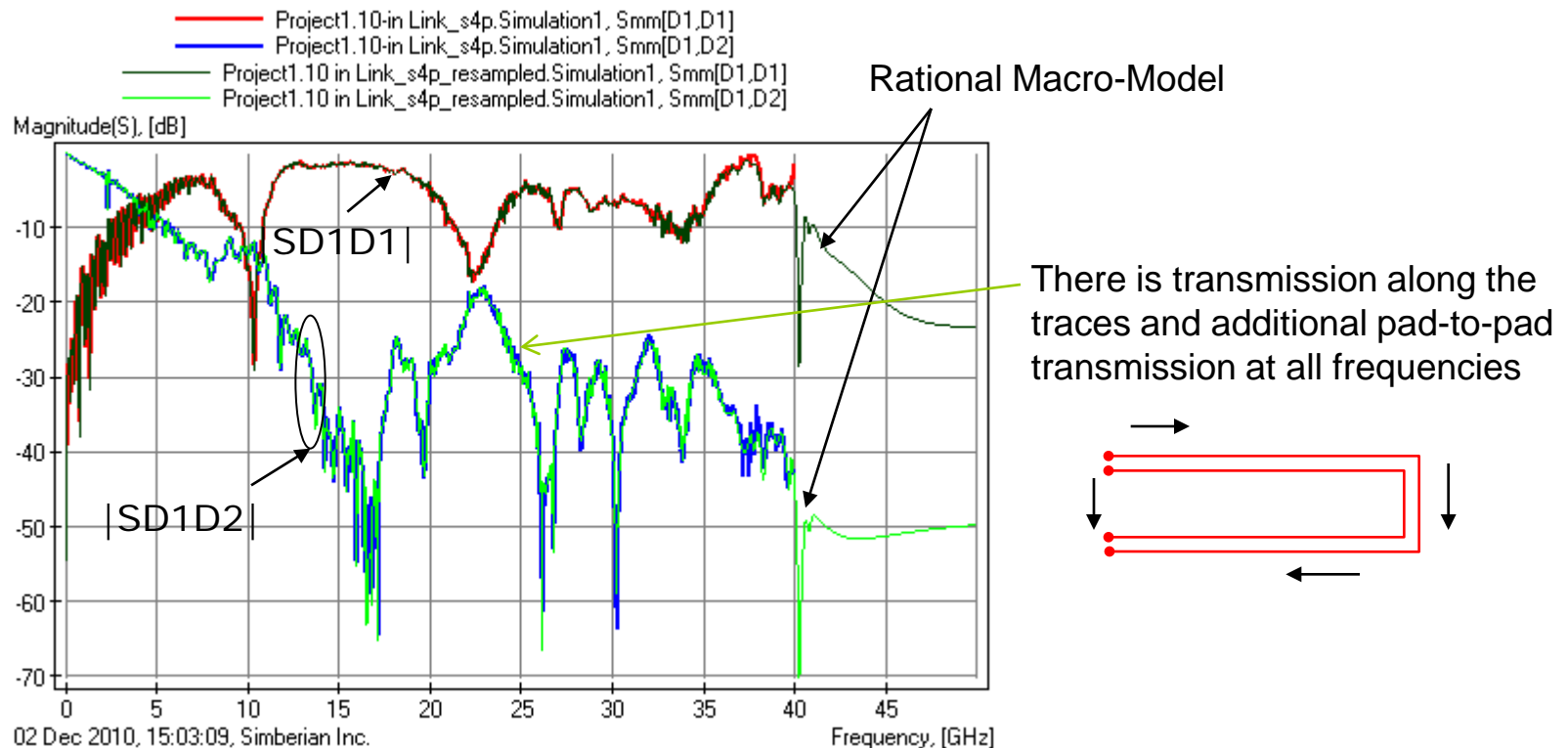

Acceptable Measured Model Example: U-shaped differential link TDT

- 40 ps 10-90% Gaussian step response (-20 dB at 22 GHz, -40 dB at 31 GHz)

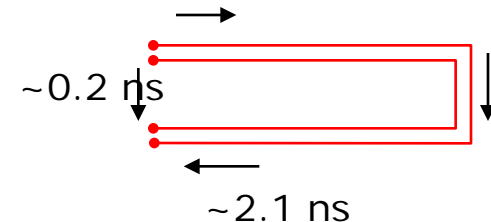
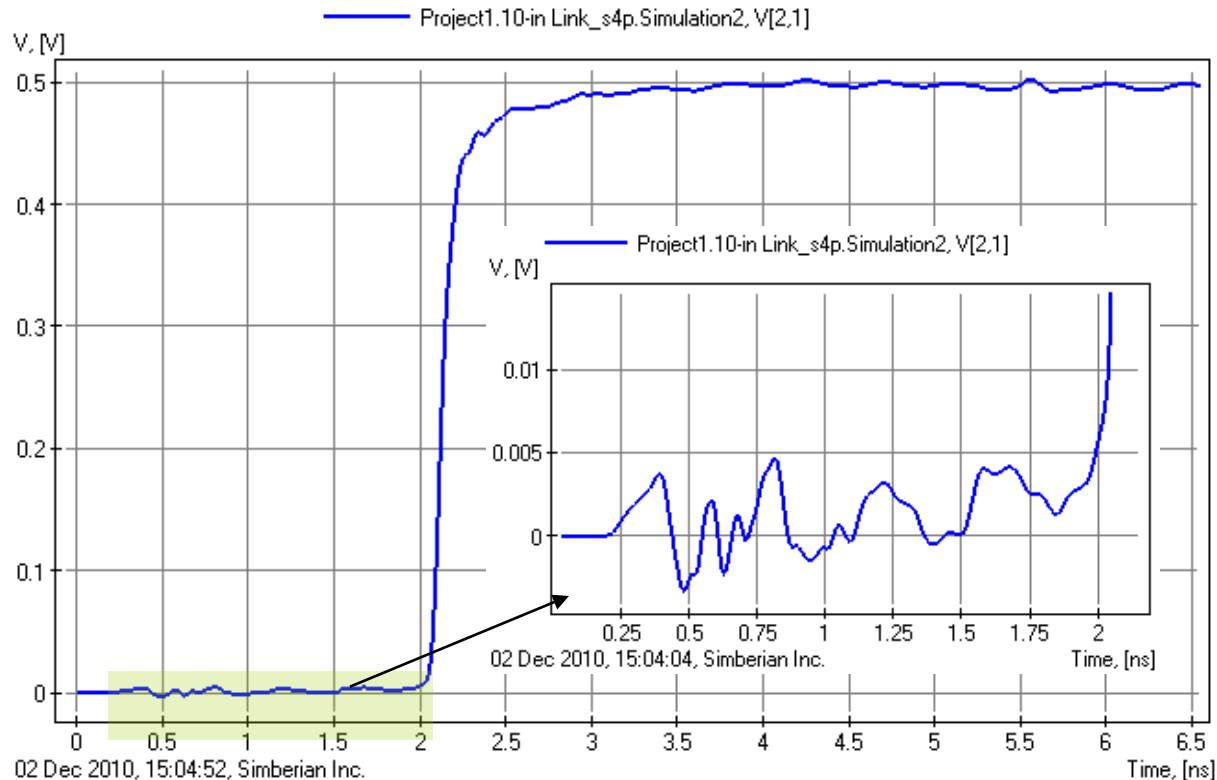

- The response shows clearly that there are “shortcuts” in the system
- Any “causality enforcement” may be erroneous for such cases!

Conclusion

- ❑ Models must be appropriately sampled over the bandwidth matching the signal spectrum
- ❑ Reciprocity, passivity and causality of interconnect component models must be verified before use
 - Both measured and computational models may have severe problems and not acceptable for any analysis
- ❑ Rational macro-models with controlled accuracy over the model frequency band can be used to
 - Do consistent frequency and time domain analyses
 - **Estimate quality of the tabulated models**
- ❑ Bad models with small quality metrics must be discarded

Contact and resources

- ❑ Yuriy Shlepnev, Simberian Inc.
shlepnev@simberian.com
Tel: 206-409-2368
- ❑ Free version of software used to plot and estimate quality of S-parameters is available at www.simberian.com
- ❑ To learn more on S-parameters quality see the following presentations (also available on request):
 - Y. Shlepnev, Quality Metrics for S-parameter Models, DesignCon 2010 IBIS Summit, Santa Clara, February 4, 2010
 - H. Barnes, Y. Shlepnev, J. Nadolny, T. Dagostino, S. McMorrow, Quality of High Frequency Measurements: Practical Examples, Theoretical Foundations, and Successful Techniques that Work Past the 40GHz Realm, DesignCon 2010, Santa Clara, February 1, 2010.
 - E. Bogatin, B. Kirk, M. Jenkins, Y. Shlepnev, M. Steinberger, How to Avoid Butchering S-Parameters, DesignCon 2011