

IBIS MODELING COOKBOOK
For IBIS Version 4.0
Review Draft 3

Prepared By:
The IBIS Open Forum

Last revised July 22, 2005

Senior Editor:
Michael Mirmak, Intel Corporation

Contributors:
John Angulo, Mentor Graphics Corporation
Ian Dodd, Mentor Graphics Corporation
Lynne Green, Green Streak Programs
Syed Huq, Cisco Systems
Arpad Muranyi, Intel Corporation
Bob Ross, Teraspeed Consulting Group

From an original by Stephen Peters published 1997

Copyright © 2005 The IBIS Open Forum. All Rights Reserved.

TABLE OF CONTENTS

1.0	INTRODUCTION.....	6
1.1	OVERVIEW OF AN IBIS FILE	6
1.2	STEPS TO CREATING AN IBIS MODEL	7
2.0	PRE-MODELING STEPS.....	8
2.1	BASIC DECISIONS	8
2.1.1	<i>Model Version and Complexity</i>	8
2.1.2	<i>Specification Model versus Part Model</i>	9
2.1.3	<i>Minimum and Maximum Corners</i>	9
2.1.4	<i>Inclusion of SSO Effects</i>	9
2.2	INFORMATION CHECKLIST	10
2.3	COMPONENT BUFFER GROUPING	11
3.0	EXTRACTING THE DATA – SINGLE-ENDED BUFFERS	12
3.1	EXTRACTING I-V DATA FROM SIMULATIONS.....	12
3.1.1	<i>Sweep Ranges</i>	15
3.1.2	<i>Voltage References</i>	15
3.1.3	<i>Diode Models</i>	16
3.1.4	<i>Diode Models</i>	16
3.2	EXTRACTING RAMP RATE OR V-T WAVEFORM DATA FROM SIMULATIONS	17
3.2.1	<i>Extracting Data for the [Ramp] Keyword</i>	17
3.2.2	<i>Extracting Data for the Rising and Falling Waveform Keywords</i>	19
3.2.3	<i>Minimum Time Step</i>	20
3.2.4	<i>Multi-Stage Drivers</i>	20
3.3	EXTRACTING BUFFER CAPACITANCE (C_COMP).....	20
3.3.1	<i>C_comp_pullup, C_comp_pulldown, C_comp_power_clamp, and C_comp_gnd_clamp</i>	22
3.4	OBTAINING I-V AND SWITCHING INFORMATION VIA LAB MEASUREMENT	23
4.0	EXTRACTING THE DATA – DIFFERENTIAL BUFFERS.....	25
4.1	INTRODUCTION	25
4.2	DIFFERENTIAL RECEIVERS	27
4.3	DIFFERENTIAL DRIVERS	29
4.4	ON-DIE TERMINATION	32
4.5	DIFFERENTIAL BUFFER MODELING WITH IBIS	33
4.6	DATA EXTRACTION	35
4.6.1	<i>Extracting Common Mode I-V Tables</i>	35
4.6.2	<i>Extracting the Differential Mode I-V Surfaces</i>	37
4.6.3	<i>Separating the On-die Termination I-V Tables</i>	39
4.6.4	<i>Extracting V-T Table Data</i>	40
4.6.5	<i>Additional Notes on Differential Data Extraction</i>	41
4.7	C_COMP AND DIFFERENTIAL BUFFER CAPACITANCE (C_DIFF).....	42
5.0	PUTTING THE DATA INTO AN IBIS FILE.....	45
5.1	BASIC SYNTAX: KEYWORDS AND THEIR DEFINITIONS.....	45
5.1.1	<i>IBIS File Header Information</i>	45
5.1.2	<i>Component and Pin Information</i>	46
5.1.3	<i>The [Model] Keyword</i>	47
5.2	DATA CHECKING	61
5.2.1	<i>Data Completeness</i>	61
5.2.2	<i>I-V and V-T Matching</i>	61
5.3	DATA LIMITING	64
5.4	ADDITIONAL RECOMMENDATIONS	65
5.4.1	<i>Internal Terminations</i>	66

5.4.2	<i>V-T Table Windowing</i>	69
5.5	ADVANCED KEYWORDS AND CONSTRUCTS	70
5.5.1	<i>[Model Selector]</i>	70
5.5.2	<i>[Submodel]</i>	71
5.5.3	<i>[Model Spec]</i>	72
5.5.4	<i>[Diff Pin]</i>	73
5.5.5	<i>[Driver Schedule]</i>	73
5.5.6	<i>[Pin Mapping]</i>	77
5.5.7	<i>Series Elements</i>	80
5.5.8	<i>[Test Data] and Reference Waveforms</i>	84
6.0	VALIDATING THE MODEL	85
7.0	CORRELATING THE DATA	86
8.0	RESOURCES	87

INDEX OF FIGURES

Figure 3.1 – Standard 3-state Buffer (Pulldown I-V Table Extraction Shown).....	13
Figure 3.2 – Simulation Setup for Extracting Ramp Rate Information (Rising Edge Shown)	18
Figure 3.3 – Fixture for Extraction of C_comp Information.....	21
Figure 3.4 – Surface Plot of Buffer Capacitance versus Frequency and DC Bias Voltage.....	22
Figure 3.5 – Fixture for Extraction of C_comp Information.....	23
Figure 4.1 – Device with Independent Input, Output and Power Supply Ports	25
Figure 4.2 – Device with Ports Using Common Ground	26
Figure 4.3 – Input Port with Locally Generated Reference	26
Figure 4.4 – Single-ended Receiver	27
Figure 4.5 – Fully Differential Receiver	28
Figure 4.6 – Half-differential Receiver	28
Figure 4.7 – Pseudo-differential Receiver.....	29
Figure 4.8 – Single-ended Driver.....	30
Figure 4.9 – Fully Differential Driver with External Load.....	30
Figure 4.10 – Half-differential Driver with External Load.....	31
Figure 4.11 – Pseudo-differential Driver Example	32
Figure 4.12 – Block Diagram of a Fully Differential Model using IBIS Version 3.2 Constructs	34
Figure 4.13 – I-V Table Extraction Fixture for a Differential Buffer	36
Figure 4.14 – Surface Plots of Raw Data from I-V Sweep of Differential Buffer.....	36
Figure 4.15 – I-V Curves of Common Mode Characteristics of Differential Buffer	37
Figure 4.16 – Differential Current Plot of Output Current versus P and N Voltage.....	37
Figure 4.17 – Plots of Various Vds Values for a [Series MOSFET] Buffer	39
Figure 4.18 – V-T Table Extraction Fixture for a Differential Buffer	41
Figure 4.19 – Fixture for Extraction of Differential Buffer C_comp.....	43
Figure 4.20 – Surface Plot of Differential Capacitance versus Frequency and DC Bias Voltage	44
Figure 5.1 – Conceptual Diagram of Model Keyword Structure	50
Figure 5.2 – Model Keyword Structure with Added Diode Detail	50
Figure 5.3 – Raw I-V and Extrapolated Final [GND Clamp] Data Graphs	53
Figure 5.4 – Graph of [GND Clamp] I-V Table Data	53
Figure 5.5 – Raw I-V and Extrapolated Final [POWER Clamp] Data Graphs.....	54
Figure 5.6 – Graph of [POWER Clamp] I-V Table Data after Clamp Subtraction	55
Figure 5.7 – Graph of [Pulldown] I-V Table Data, after Clamp Subtraction.....	56
Figure 5.8 – Graph of [Pullup] I-V Table Data after Clamp Subtraction.....	56
Figure 5.9 – Diagram of Resistive Load for Rising Waveform	62
Figure 5.10 – V-T Table Loading Example	62
Figure 5.11 – V-T Table Loading Example, Simplified	63
Figure 5.12 – [Pullup] I-V Table Data with Load Line Intercept	64
Figure 5.13 – Data Point Selection Example	65
Figure 5.14 – Diagram of I/O Buffer with Internal Termination	66
Figure 5.15 – Raw I-V Table Clamp Data for Ground-connected Termination	67
Figure 5.16 – Graph of I-V Data for Ground Terminated Buffer in High-Impedance State.....	68
Figure 5.17 – Graph of Power and Ground Clamp I-V Data for Vcc-connected Termination	68
Figure 5.18 – Graph of I-V Data for Vcc Terminated Buffer in High-Impedance State	69
Figure 5.19 - Block Diagram of a Two-Tap Differential Buffer Featuring Pre-Emphasis	75
Figure 5.20 – Output of a Scheduled Driver Configured as an Inverter	76
Figure 5.21 – Component Diagram Showing Buffer and Supply Buses.....	78
Figure 5.22 – Connection of Single-ended and Series [Model]s	80

INDEX OF TABLES

Table 3.1 – Recommended Load Circuits and Waveforms for V-T Data Extraction	19
Table 5.1 – IBIS File Header Keywords	46
Table 5.2 – IBIS Component and Pin Information	47
Table 5.3 – IBIS [Model] Subparameters	48
Table 5.4 – IBIS [Model] Temperature and Voltage Keywords	49
Table 5.5 – [Model] I-V Table Keywords.....	51
Table 5.6 – Summary of Recommended I-V Table Sweep Ranges	57
Table 5.7 – Poorly Extrapolated [GND Clamp] Table, Typical Corner	57
Table 5.8 – [GND Clamp] Table, Typical Corner, with Improved Extrapolation	57
Table 5.9 – [Ramp] and Waveform Table Keywords	58
Table 5.10 – I-V Table Keywords and Buffer Types.....	59
Table 5.11 – V-T Fixtures and Buffer Types	60
Table 5.12 – V-T Table Loading Recommendations	60
Table 5.13 - Example V-T Table Data for Rising Waveform.....	62

1.0 Introduction

This document describes the recommended steps for producing IBIS files for digital integrated circuits (ICs). IBIS (officially, EIA standard 656-A-1999, IEC 62014-1) stands for I/O Buffer Information Specification. IBIS models provide a standardized way of representing the electrical characteristics of a digital IC's pins (input, output, I/O buffers and the like) behaviorally, i.e., without revealing the underlying circuit's structure or process information.

Note that the basic behavioral information in an IBIS model can be obtained either by direct measurement of the component or transistor level simulation of the component's buffers. This cookbook describes both methods, though with a strong emphasis on data extraction through simulation. The cookbook is targeted towards generating models for CMOS, GTL and bipolar parts, and applies to models generated for IBIS version 4.0 and earlier. For the most recent version of the specification and other IBIS documents, visit the IBIS web page (see the *Error! Reference source not found.* section).

The intended audience of this document is those responsible for performing the measurements or simulations to gather I/O buffer data, as well as those responsible for actual IBIS model creation. Persons involved in SI or system level PC board simulations using IBIS files may also benefit by reading this document. Some familiarity with behavioral modeling of I/O buffers and analog simulation is assumed. Finally, this document does not address every keyword or feature of the IBIS specification and should not be considered a substitute for the specification itself. Readers are strongly encouraged to study closely the details of the IBIS specification.

1.1 Overview of an IBIS File

An IBIS file contains, in a human readable ASCII format, the data required to model behaviorally a component's input, output and I/O buffers. Specifically, the data in an IBIS file is used to construct a buffer model useful for performing signal integrity (SI) simulations and timing analysis of printed circuit boards. The fundamental information needed to perform these simulations is the buffer's I-V (current versus voltage) and switching (output voltage versus time) characteristics. Please note that the IBIS specification does NOT define an executable simulation model – it is a standard for the formatting and transfer of data. As such, the specification defines what the information included in an IBIS file represents and how it is to be gathered. It does not specify what an analog simulation application does with the data.

IBIS models are component-centric. That is, an IBIS file allows one to model an entire component, not just a particular buffer. Therefore, in addition to the electrical characteristics of a component's buffers, an IBIS file includes the component's pin-to-buffer mapping, and the electrical parameters of the component's package.

In general, an output or I/O buffer is characterized behaviorally using the following information:

- The buffer's output I-V characteristics when the output is in the logic low state
- The buffer's output I-V characteristics when the output is in the logic high state
- The buffer's output I-V characteristics when the output is forced below ground and above the power supply rail (referred to as its "beyond the rail" characteristics)
- The time it takes a buffer's output to switch logic states (i.e., from low to high and high to low)
- The buffer's capacitance

For an input buffer the required information reduces to:

- The buffer's I-V characteristics (including its "beyond the rail" characteristics)
- The buffer's capacitance

The above information is included in an IBIS file using “keywords”. A keyword is a word or phrase surrounded by square brackets. Keywords are followed by either specific parameters or tables of data. For instance, the [Model] keyword would be used to encapsulate the I-V and V-T tables, plus other data, for an individual single-ended I/O buffer. Some keywords are required, but most are optional. At a minimum, a valid IBIS file contains the following data and keywords:

1. Information regarding the file itself and name of the component being modeled. This information is contained under the keywords [IBIS Ver], [File Name], [File Rev], [Component] and [Manufacturer].
2. Information about the package’s electrical characteristics and the pin to buffer model mapping (i.e., which pins are connected to which buffer models). This information is included under the [Package] and [Pin] keywords.
3. The data required to model each unique input, output and I/O buffer design on the component. The [Model] keyword introduces the data set for each unique buffer. As described above, buffers are characterized by their I-V behaviors and switching characteristics. This information is included using the keywords [Pullup], [Pulldown], [GND Clamp], [POWER Clamp] and [Ramp]. In addition, the required parameters to the [Model] keyword specify a model’s type (Input, Output, I/O, Open_drain, etc.) and its input or output capacitance.

The details of constructing an IBIS model from data are included in *Putting the Data into an IBIS File* later in this document.

1.2 Steps to creating an IBIS Model

There are five basic steps to creating an IBIS model of a component:

1. Perform the pre-modeling activities. These include deciding on the model’s complexity, determining the voltage, temperature and process limits over which the IC operates and the buffer model will be characterized, and obtaining the component related (electrical characteristics and pin-out) and use information about the component. See the chapter titled *Pre-Modeling Steps*.
2. Obtain the electrical (I-V and switching response) data for output or I/O buffers either by direct measurement or by simulation. See the chapter entitled *Extracting the Data*. This chapter may also be used by those who are doing the simulations required to gather the data but not actually creating the IBIS file.
3. Format the data into an IBIS file. See the chapter titled *Putting the Data into an IBIS File*.
4. Check the file using IBISCHK4. If the model is generated from simulation data, validate the model by comparing the results from the original analog (transistor level) model against the results of a behavioral simulator that uses the IBIS file as input data. See the chapter titled *Validating the Model*.
5. When the actual silicon is available (or if the model is from measured data), compare the IBIS model data to the measured data. See the chapter titled *Correlating the Data*.

The rest of this cookbook documents these steps in detail.

2.0 Pre-Modeling Steps

2.1 Basic Decisions

Before one creates an I/O buffer model there are several basic questions that must be answered regarding the model's complexity, operational limits, and use requirements. Answering these questions requires not only knowledge of the buffer's physical construction, but also knowledge of the final application in which the IC will be used, and any specific requirement the model users may place on the model. These questions cannot be answered by the model creator alone; they generally require the involvement of both the buffer designer and members of the team responsible for insuring that the I/O buffers are useable in a system environment. This team is referred to as the interconnect simulation team. Together, the model creator and interconnect simulation team must determine the following:

- Model Version and Complexity
- Specification Model versus Part Model
- Fast and Slow Corner Model Limits
- Inclusion of SSO Effects

2.1.1 Model Version and Complexity

Based on the characteristics and construction of the I/O buffer itself, and the model user's simulator capability, you must decide what IBIS version of the model is most appropriate. Different IBIS versions, as denoted by the [IBIS Ver] keyword, support different features. Additionally, the checking rules used by IBISCHK4 change slightly with each version. In general, models should use the highest [IBIS Ver] version number supported by IBISCHK4 and by their simulation tools (see *Validating the Model***Error! Reference source not found.**). Similarly, following good engineering practice, use the simplest model that will suffice.

A version 1.1 model describes a buffer using a low state and high state I-V table, along with a linear ramp that describes how fast the buffer switches between states. For standard CMOS buffers with a single stage push-pull or open-drain outputs, a version 2.1 model is the recommended minimum. IBIS version 2.1 adds support for tables of V-T data, in addition to support for ECL and dual-supply buffers, ground bounce from shared power rails, differential I/O buffers, termination components, and controlled rise-time buffers. A version 2.1 or above model will be required if the I/O buffer has any of the following characteristics:

- Multiple Supply Rails – A version 2.1 (or higher) model is required if the buffer contains diode effects – from parasitic diodes or electrostatic discharge (ESD) diodes – which are referenced to a different power rail than the pullup or pulldown transistors, or if the I/O uses more than one supply.
- Non-Linear Output Switching Waveform – A version 2.1 (or higher) model is required if the I/O buffer's output voltage versus time behavior (its V-T behavior) when switching low-to-high or high-to-low cannot be accurately described using a linear ramp rate value. This is the case for GTL technology, or for any buffer that uses “graduated turn on” type technology.
- In addition, a version 2.1 model description is required if the model maker wishes to enable the user to perform ground bounce simulations by connecting several buffers together on a common supply rail. See the [Pin Mapping] keyword description below.

IBIS version 3.2 adds support for an electrical board description format, multi-staged buffers or buffers that may use multiple I-V tables and diode transient times, among other features. IBIS version 4.0 extends the maximum number of points permitted in V-T tables, supports the inclusion of independent validation data tables and adds more parameters for expressing “databook” criteria for evaluating buffer performance.

2.1.2 Specification Model versus Part Model

A model can be made to represent a particular existing component or can be made as a representative encapsulation of the limits of the specification for a class of components. Making a model appropriate for a specification versus a particular part or design is a major factor in determining if and how much guard-banding or de-rating a model requires. Generally, a “spec model” is based on an existing part, with the strength and edge rate of the model is adjusted to meet the best and worst case parameters of a particular specification. For example, a GTL buffer model for a particular processor may give a worst case Vol of 0.4 V at 36 mA. However, if the GTL specification allows for a worst case Vol of 0.6 V at 36 mA the model’s pulldown table may be adjusted (or de-rated) to describe the specification and not just the behavior of an individual part.

2.1.3 Minimum and Maximum Corners

The IBIS format provides for minimum, typical and maximum corner data within each individual model. Further, additional variations can be associated through keywords such as [Model Selector] (see below). The model corners are generally determined by the environmental (temperature and power supply) conditions under which the silicon is expected to operate and the silicon process limits. Note that the definitions for “typical,” “minimum” and “maximum” are not defined by the IBIS specification. Generally, however, common usage associates the “minimum” corner with the weakest drive strength and/or slowest edge rate, while the “maximum” corner is associated with the strongest drive and/or fastest edge rate.

The interconnect team or project must supply the model developer with the environmental and silicon process conditions that define the corners of the model for proper data extraction. *Please note that for an output buffer model to be useful for flight time simulations these conditions MUST match those used for specifying the buffer output timing delay parameters.*

2.1.4 Inclusion of SSO Effects

Closely related to the discussion on model limits is the decision on how to include simultaneous switching output (SSO) effects (sometimes called simultaneous switching noise). SSO effects can be included explicitly in a model by measuring the I-V and edge rate characteristics under SSO conditions. For example, a buffer’s I-V characteristic can be measured with all the adjacent buffers turned on and sinking current, or the buffer’s edge rate may be measured while adjacent buffers are also switching. Alternatively, a model that represents a single buffer in isolation may be created. Several such buffers may then be connected to a common power or ground rail via the [Pin Mapping] keyword. The former method (including SSO effects in the I-V and V-T tables) has the advantage that the resulting model is straightforward to verify and less dependent on any particular simulator’s capability. Note however, the [Pin Mapping] keyword method also adds data to enable explicit ground bounce simulations and device-specific “what if” scenarios.

Note that the information provided under IBIS version 4.0 and earlier versions only describes the output behavior of buffers under loaded conditions. Therefore, SSO simulations will only be based on the behavior at the pad and not upon information extracted about the current profile of the supplies as the buffer switches. Different distributions of internal buffer current may result in the same behavior at the pad. Different simulation tools may therefore make radically different assumptions regarding SSO behavior for the same IBIS data. Check with your simulation tool vendor for details on their specific assumptions and IBIS SSO simulation algorithms.

2.2 Information Checklist

Once the above decisions have been made, the model maker can begin acquiring the specific information needed to generate the IBIS model for the component. Some of this information is specific to the component as a whole and goes directly into the IBIS file itself, while some items are needed to perform the required simulations. In general, the model maker will need the following:

IBIS Specification	Acquire, read and become familiar with the IBIS specification.
Buffer Schematics	Acquire a schematic of each of the different types of input, output, I/O, etc. buffers on the component. If possible, use the same schematic that the silicon designers use for simulating buffer output timings. Make sure that the schematic includes ESD diodes (if present in the design) and a representation of the power distribution network of the package. From these schematics, determine the type of each buffer structure (standard CMOS totem pole, open-drain, etc.) on the component.
Clamp Diode and Pullup References	Determine if the buffer uses different voltage references (power and/or ground supply rails) for the clamp diodes than those used for the pullup or pulldown transistors. This may apply for components that are designed for use in mixed 3.3 V/5 V systems.
Packaging Information	Find out in what packages the component is offered. A separate IBIS model is required for each package type. Acquire a pinout list of the component (pin name to signal name mapping) and determine the pin name to buffer type mapping.
Packaging Electricals	Acquire the electrical characteristics (inductance, capacitance and resistance) of the component's package for each pin to buffer connection (package stub). This becomes the R_pin, L_pin and C_pin parameters of the [Pin] keyword or the R_pkg, L_pkg and C_pkg of the [Package] keyword.
Signal Information	Determine which signals can be ignored for digital component modeling purposes. For example, purely analog pins cannot be modeled using IBIS 4.0, while test pads or static control signals may not need an IBIS model. These may be listed as NC in the [Pin] list.
Die Capacitance	Obtain the capacitance of each pad (the C_comp parameter). This is the capacitance seen when looking from the pad into the buffer for a fully placed and routed buffer design, exclusive of package effects (note that the phrases "Cdie" or "die capacitance" may be used in other industry contexts to refer to the capacitance of the entire component as measured between the power and ground supply rails).
Vinl and Vinh Parameters	Determine the input logic thresholds of any input or I/O buffers. Vinl is the maximum pad or pin voltage at which the receiving buffer's logical state would still be a logical "low" or "0." Vinh is the minimum

pad or pin voltage at which the receiving buffer's logical state would still be a logical "high" or "1." Note that IBIS version 4.0 permits advanced threshold descriptions, including different AC and DC switching voltages plus hysteresis effects.

Timing Measurement Conditions

Find out under what loading conditions an output or I/O buffer's output delay timing information (propagation delay of the signal from clock input to driven output; sometimes called "Tco") is measured. This includes the load capacitance, resistance and/or voltage (Cref, Rref and Vref parameters) as well as the output voltage crossing point at which the timing delay is measured (the Vmeas parameter).

2.3 Component Buffer Grouping

One of the first tasks when building an IBIS representation of a component is to determine how many individual buffer models have to be created. Separate buffer models are required for each different buffer design the component uses. Begin by first separating a component's pins into buffer types: inputs, outputs, I/Os and the like. Then for each group of pins determine how many unique buffer designs are present. For example, a clock input may have a different input design or diode structure than the rest of the component's inputs. Also, be aware that even if all the output or I/O pins are driven by buffers of the same design, separate output or I/O models may be required if a group of signals have different C_comp parameters or buffer delay measurement conditions. Once the number of separate buffer models has been determined, the actual model creation process can begin.

3.0 Extracting the Data – Single-ended Buffers

Once the pre-modeling steps have been performed, the process of gathering the required I-V and switching information can begin. Output and I/O buffers demand both I-V tables and rise/fall data, while input buffers in most cases only demand I-V tables. There are two ways to get this information:

- For pre-silicon models use circuit simulation tools to obtain the information over the worst cases of process and temperature variations, then correlate the model against the actual silicon.
- When the actual silicon is available, one can use the data from physical measurements to build the model. However, obtaining worst-case min and max data over process and temperature may be difficult using physical data. Further, models created from measurement may show significant noise.

The first sections of this chapter explain how to obtain the I-V and switching information from a transistor-level model of the buffer, either by use of an automated simulation template or extraction tool (such as S2IBIS3) or by doing your own simulations. *Obtaining I-V and Switching Information via Lab Measurement* later in this chapter explains how to gather this information via measurement. The reader is assumed to have some background in doing transistor level simulations and/or the use of lab equipment.

Totem pole CMOS structures are assumed for most of the text below. Some adjustments will be necessary for designs such as open-source, etc.

3.1 Extracting I-V Data from Simulations

The first step to extracting the required I-V tables is understanding the buffer's operation. Analyze the buffer schematic and determine how to put the buffer's output into a logic low, logic high and (if applicable) high impedance (3-state) state. As mentioned above, the schematic should include any ESD or protection diodes. Also, understand the buffer's power supply voltage reference ("Vcc") requirements and connections. The schematic should also indicate if the power clamp and/or ground clamp diode structures are tied to voltage rails (voltage references) different from those used by the pullup and/or pulldown transistors.

3.1.1.1 Simulation Setup

A typical I-V table simulation setup for an output or I/O buffer is shown in Figure 3.1 below. For this example, the buffer being analyzed is a standard 3-state buffer with a single push-pull output stage. The buffer uses electrostatic discharge protection devices in addition to its parasitic driver diodes. The buffer's clamp supplies are assumed identical to its driver supply (Vcc hereinafter).

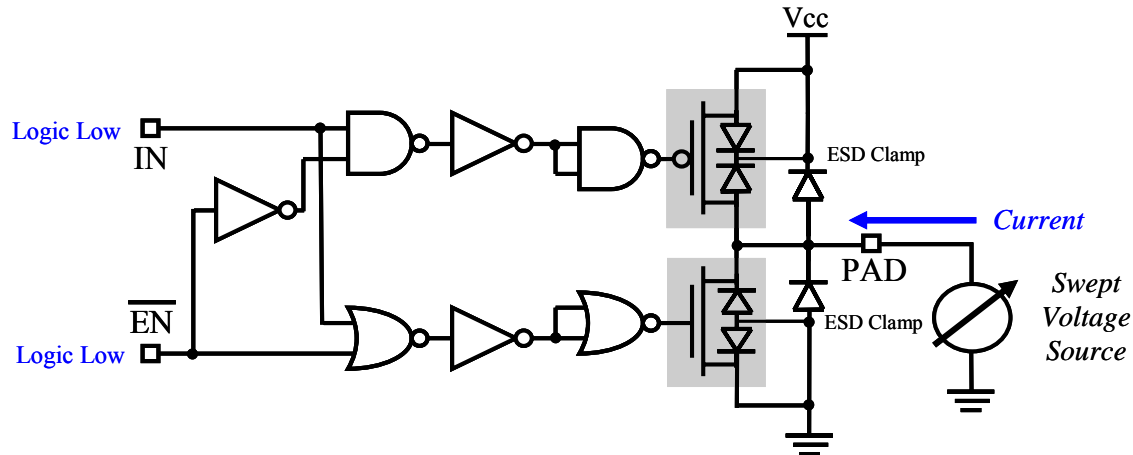

Figure 3.1 – Standard 3-state Buffer (Pull-down I-V Table Extraction Shown)

All measurements are made at the output node (pad) as shown above. Remove all package lead (R_{pin} , L_{pin} , and C_{pin}) parasitics. However, any series resistances present between the pad and the pullup/pulldown transistors should be included (these are not shown in Figure 3.1).

The output buffer is connected to an independent voltage source. Set the buffer's input(s) so that the desired output state (low, high, off) is obtained, then using a DC or "transfer function" analysis sweep the voltage source over the sweep range $-V_{cc}$ to $2*V_{cc}$ while recording the current into the buffer. An alternative method is to perform a "transient analysis". The voltage source in this case should be linear ramp function driving the output node, slow enough that the current measurement at each time point is effectively DC, without reactive aspects of the design affecting the result. The current flow into the pad is measured (by IBIS convention, current flow into the die pad is positive), as is the voltage at the node with respect to a reference, then the resulting I-T and V-T data is combined into a single I-V table. Note that a transient function analysis may require post-simulation data manipulation.

3.1.1.2 I/O and 3-State Buffers

For IBIS purposes, the driving behavior of 3-state and I/O buffers are identical. Both types are capable of driving high, driving low or being placed in a high-impedance state. For these buffers, four sets of I-V tables are generally included; one with the pulldown transistor turned on (output in the low state), one with the pullup transistor turned on (output in the high state), and two with the output in a high-impedance state. The data gathered while the output is in the low state is used to construct the [Pull-down] table. Data gathered when the output is in the high state is used to construct the [Pull-up] table. Pull-down I-V data is referenced to ground while pullup I-V data is referenced to V_{cc} (referencing pullup data to V_{cc} means that the voltages measured will be expressed in terms of their potential difference from V_{cc} . For example, "0 V" for a V_{cc} -relative measurement is equivalent to " V_{cc} " when measured ground-relative. Refer to *Voltage References* for more details). Data for the [GND Clamp] keyword is taken with the output in the high impedance state and is ground-relative, while data for the [POWER Clamp] keyword is also taken with the output in a high impedance state but with the data V_{cc} -relative. For each keyword, a typical set of tables must be included; data for minimum and maximum corner conditions may be included. If corner data is present, it must cover the entire sweep range.

Thus, a 3-state or I/O buffer would optimally include the following 12 I-V data sets:

- Pull-down I-V under minimum, typical and maximum conditions, data ground-relative
- Pullup I-V under minimum, typical and maximum conditions, data V_{cc} -relative
- High impedance state I-V under minimum, typical and maximum conditions, data ground-relative

- High impedance state I-V under minimum, typical and maximum conditions, data Vcc-relative

IBIS does make a distinction between I/O and 3-state buffers in terms of their receiving behaviors. 3-state buffers cannot function as receivers and so should never include `Vinh` or `Vinl` subparameters, or any other input-related IBIS features.

3.1.1.3 Output Buffers

For an output buffer (i.e., a buffer which cannot receive or be placed in a high-impedance state), only two sets of tables are needed; one with the pulldown transistor turned on (output in the low state), and one with the pullup transistor turned on (output in the high state). As before, pulldown I-V data is referenced to ground while pullup I-V data is referenced to `Vcc`. Because an output buffer does not have a high-impedance state, the power and ground clamp diode tables cannot be isolated from the transistor tables; the data for behavior beyond the rails is simply included in the final IBIS [Pullup] and [Pulldown] I-V tables. The [GND Clamp] and [POWER Clamp] keywords are not required for an output buffer.

3.1.1.4 Open-Drain, Open-Sink and Open-Source Buffers

Open-drain buffers are assumed to contain no switched pullup devices. Therefore, IBIS models using the “Open_drain” or “I/O_open_drain” Model_type contain no [Pullup] data. For input-capable open-drain buffers (the “I/O_open_drain” Model_type in IBIS), three sets of I-V data: [Pulldown], [GND Clamp] and [POWER Clamp] are generally recommended. For output-only open-drain buffers (the “Open_drain” Model_type in IBIS), the [Pulldown] I-V data, at a minimum, should be present, but wherever possible, separate clamp data should be included (see *Diode Models* below)

Data for the [Pulldown] table is gathered as described previously for I/O and output-only buffers. The [POWER Clamp] and [GND Clamp] data is gathered by turning off the pulldown transistor then performing the two I-V sweeps as described above for an I/O buffer in the high impedance state. Refer to *Sweep Ranges* and *Diode Models* below for more information on clamp extraction procedures.

Note that the term “open-drain” is potentially confusing in an IBIS context, as different design techniques can be used to construct pulldown-only or pullup-only buffers that are still technically “open-drain” (e.g., a PMOS pullup), even though the IBIS “Open_drain” Model_type only describes pulldown-only designs. For this reason, the IBIS Model_type subparameters “Open_sink” and “Open_source” were introduced in IBIS version 2.1 to describe more clearly the buffer being modeled. Open_sink buffers “sink” current when driving, and therefore contain a [Pulldown] but no [Pullup]. Open_source buffers “source” current when driving, and therefore contain a [Pullup] but no [Pulldown].

Note that, even if there is no enable on a pulldown-only output-only buffer, it can still be placed in a high-impedance state by putting it in a high state. Clamping effects and any internal terminations will appear in the resulting raw I-V sweep data, without the behaviors of driving transistors (see *Diode Models* below for more information). Similarly, a pullup-only output-only buffer can be effectively put into a high-impedance state by putting it in a low state. This technique may not be possible on complementary output buffers, however. In this case, more sophisticated numerical data processing may be needed to extract the clamp data from the raw measured or simulated data.

3.1.1.5 Input Buffers

When gathering I-V data for input buffers the same general setup is used, only the variable voltage source is placed on the input node. Input buffers generally contain only [POWER Clamp] and [GND Clamp] I-V data, though [POWER Clamp] only or [GND Clamp] only designs are possible (again, clamp data is never required by the IBIS specification). As with the output buffer, [GND Clamp] data is gathered via a voltage sweep with the voltage source referenced to ground and the [POWER Clamp] data is gathered by a voltage sweep with the voltage source Vcc-relative. If an input buffer includes internal resistive terminations to power and/or ground, the effects of these terminations on the I-V tables are included into the respective ground clamp or power clamp I-V data and additional post-processing is required before the data can be included in the IBIS model. See *Internal Terminations* for more information.

3.1.2 Sweep Ranges

As per the IBIS specification, I-V data must be supplied over the range of voltages the output could possibly generate or experience in a transmission line environment. Assuming that a buffer's output swings from ground to Vcc (where Vcc is the voltage given by the [Voltage Range] or [Pullup Reference] keywords) this range is -Vcc (the maximum negative reflection from a shorted transmission line) to 2*Vcc (the maximum positive reflection from an open-circuited transmission line). However, be aware that if a buffer is operating in an environment where its output could be actively driven beyond these limits the I-V table must be extended further. Consider, for example, a 3.3 V I/O buffer operating in a mixed 3.3 V/5 V system. While the buffer's output may only drive from 0 to 3.3 V, a five-volt buffer connected to this output may drive the output node beyond 3.3 V volts. In this case, I-V data should be supplied over a full -5 V to +10 V range. Likewise, an open-collector or open-drain buffer may be terminated in a voltage (Vpullup) different from that given by the [Voltage Range] keyword. In this case it is recommended to supply the pullup and pulldown data over the range -Vpullup to 2*Vpullup.

Semiconductor buffer models may not be well behaved over these ranges, so one may reduce the actual sweep range and use extrapolation to get to the required endpoints. For example, suppose one were attempting to gather the I-V data for a typical 5 V buffer. The IBIS specification requires I-V data over the full -5 V to +10 V range. The model maker may choose to limit the simulation sweep to -2 V to +7 V, and then extrapolate to the final -5 V to +10 V range. Be aware however, that the simulation sweep range must be enough to forward-bias any ESD protection diodes or parasitic diode structures.

3.1.3 Voltage References

Pullup and power clamp voltages in IBIS I-V tables are assumed to be Vcc-relative (where the value of Vcc is given by the [Voltage Range] keyword), while the pulldown and ground clamp voltages in the I-V tables are assumed to be referenced to the buffer's local ground. For example, the 0 V entry in the pullup table and the 0 V entry in the pulldown I-V table are not the same voltages; rather, they correspond to Vcc and ground, respectively, as measured relative to ground.

Pullup and power clamp I-V data is relative to the buffer supply for two reasons:

1. Power rail noise due to buffer switching effects can be simulated more accurately, as the pullup and power clamp will interact with the power supply differently from its interactions with the ground supply.

2. Graphical comparison of pullup and power clamps is simpler across multiple corners and supply voltages. For example, the minimum, typical and maximum curves for a buffer power clamp without internal termination effects, plotted V_{cc} -relative, will all cross through the origin of the plot.

For these reasons, I-V data for pullups and power clamps may be collected in two ways:

1. The voltage source used for sweeping the pad may be connected between the pad and V_{cc} rather than the pad and ground. Data collected in this way may be placed in the final IBIS file with minimal editing.
2. The voltage source used for sweeping the pad may be connected between the pad and ground, as was shown earlier for ground clamp and pulldown data. This means that the raw pullup and power clamp I-V data must be converted to use V_{cc} as a reference before being used in an IBIS file.

Note that the range requirements in the IBIS specification use IBIS referencing assumptions; the pullup and power clamp I-V table ranges are with reference to V_{cc} . Care should be taken that any I-V data taken using a ground-connected voltage sweep source cover the correct range when the data is translated to V_{cc} -referencing.

For example, consider gathering pullup I-V data for a standard 3.3 V buffer using a ground-relative sweep voltage source. Assume the V_{cc} specification for the buffer is 3.3 V +/- 10% (i.e., the operating V_{cc} ranges from 3.0 V minimum to 3.6 V maximum). The sweep voltage under typical conditions would range from +6.6 V to -3.3 V, ground-relative. However, this must appear in the final IBIS file using a voltage axis that ranges from -3.3 to +6.6 V. The ground-relative data can be made V_{cc} -relative by maintaining the order of the current data points, but discarding the original +6.6 V to -3.3 V sweep axis. By simply replacing the ground-relative axis with the -3.3 V to +6.6 V values – without reordering the current data points – the IBIS requirement is satisfied. For minimum conditions, where V_{cc} is 3.0 V, the sweep voltage should sweep from +6.3 V to -3.6 V, ground-relative. Again, this data would be placed in the final IBIS model using a -3.3 to +6.6 V range on the voltage axis, without reordering the current data points. Note that the 9.9 V sweep RANGE remains the same for all three simulations.

Note that all IBIS I-V tables may also be supplied in relation to explicit reference voltages other than [Voltage Range], using the [Pullup Reference], [POWER Clamp Reference], [Pulldown Reference] and [GND Clamp Reference] keywords. Please see *Temperature and Voltage Keywords* below for more information.

3.1.4 Diode Models

When designing digital I/O buffers most of the analysis is focused on the buffer's output delay timings and impedance. Often, very little attention is paid to a buffer's "beyond the rail" operation. Thus, the diode models included in buffer's schematic may be included for layout or completeness only, and are most likely ideal models with no intrinsic resistance or other parasitics. If the system design relies on the intrinsic diode structure of the output transistors to provide overvoltage protection, such transistor models may not properly represent operation beyond the rails.

Consequently, IBIS models made using such idealized diodes may appear to clamp more effectively in simulation than in actual silicon. Further, when simulating "beyond the rail," one may get unrealistically large (e.g., kiloamp) power and ground clamp currents. Several options are available to address these issues. The diode or transistor models can be enhanced to include the proper junction or bulk resistance, which can be relatively large in some cases (on the order of a few ohms). If a physical silicon sample is available, the model creator can measure the power and ground clamp I-V data directly.

In IBIS, clamp behavior can be expressed through the [POWER Clamp] and [GND Clamp] keywords. Technically, these clamp keywords are never required. However, the use of these keywords for all IBIS buffer types is highly recommended.

Output-only buffer models may be legally modeled under IBIS using only the [Pullup] and [Pulldown] keywords. However, even though the clamp keywords may not be present in such buffer models, clamping *effects* are present in the I-V data. In some cases, tools may provide unexpected or undesirable results for output-only buffer models that do not contain separate clamp tables. For example, an Open_sink buffer may be modeled using only a single I-V table, under the [Pulldown] keyword. If the table covers the required sweep range, the [Pulldown] I-V table will most likely include clamping diode effects. However, tools may simulate such an IBIS buffer model in a non-driving (high) state by multiplying the entire [Pulldown] table by zero. This will effectively remove any clamping effects from the simulation, even though the buffer model used correct IBIS syntax.

Therefore, separate clamp tables are recommended even for buffer Model_types that are not input-capable, such as Open-drain, Output, etc.

3.2 Extracting Ramp Rate or V-T Waveform Data from Simulations

Simulations to obtain the ramp rate and/or V-T (output voltage versus time) tables are relatively straightforward. When modeling a CMOS or TTL buffer, for each simulation corner (minimum, typical, maximum), four V-T data sets are generally recommended. Two waveforms – either featuring a load to ground or a relatively low voltage – are generated for the buffer output switching low to high. The other two waveforms – both featuring a load to Vcc or a relatively high voltage -- are generated for the buffer output switching high to low. This ramp rate (rising and falling dV/dt ratios) can be extracted from the transitions where the device is “turning on” – switching to high against a low-voltage fixture and switching to low against a high-voltage fixture -- or the actual V-T data may be reported directly. Note that the specific load conditions may vary depending on the design of the buffer. Further, be aware that the IBIS specification permits up to 100 waveforms to be included to describe buffer transitions, using a variety of loading conditions (see below).

3.2.1 Extracting Data for the [Ramp] Keyword

If the output switching (V-T) waveform of a buffer can be approximated by a linear ramp (i.e., the V-T waveform has no abrupt changes in shape, there are no “pedestals” in the waveform, etc.) then the V-T data may be reported as a rising and falling ramp rate (dV/dt) by using the [Ramp] keyword. Data for the [Ramp] keyword may be extracted using a simulation setup similar to that shown in Figure 3.2 below. Switching information can only be represented in IBIS version 1.1 through the [Ramp] keyword.

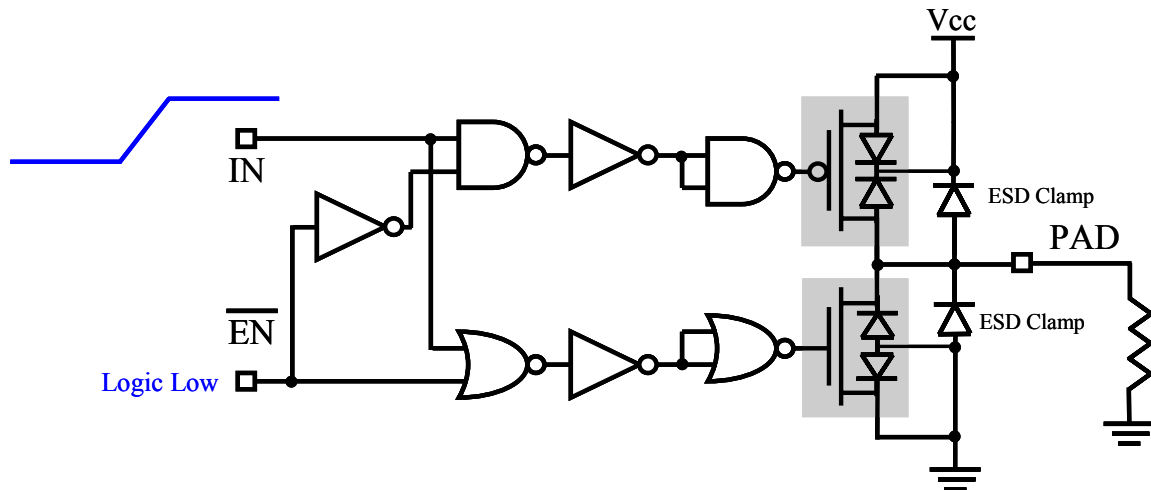

Figure 3.2 – Simulation Setup for Extracting Ramp Rate Information (Rising Edge Shown)

Obtain rise and fall time data by setting the simulator for a transient analysis simulation. The control inputs of the buffer are set to enable the buffer outputs and a driving waveform is applied to the buffer core-side input. The slew rate of the input stimulus driving waveform should be appropriate to normal use of the buffer (i.e., the slew rate of the pre-driver that would normally drive the final output stage). Rising ramp rate data is obtained by placing a load resistance from the output to ground then stimulating the buffer so that the output switches from low to high. Falling ramp data is captured with the load resistor tied to V_{cc} . In general, a load resistance of 50 ohms is recommended, but this may not be appropriate in all cases. If the buffer does not have enough drive capability to make a significant output transition then a higher value of load resistance may be used, but this must be noted in the IBIS file (see the description of the [Ramp] keyword in the IBIS specification for details). For an open-drain or ECL/PECL buffer, measure the rise and fall times into the load resistor and voltage used by the manufacturer when specifying propagation delays. As with the I-V simulations, the package lead (L_{pin} , R_{pin} , C_{pin}) parasitics must be removed. However, simulations should include C_{comp} effects.

3.2.2 Extracting Data for the Rising and Falling Waveform Keywords

In IBIS versions 2.1 and above V-T data may be reported directly by using the [Rising Waveform] and [Falling Waveform] keywords. These two keywords are strongly recommended if the output switching waveform of the buffer is significantly non-linear (this is the case with most “controlled rise time” buffer designs). The use of these keywords is also indicated if the buffer incorporates a delay between the turning off of one output transistor and the turning on of the other.

When performing simulations to extract V-T data for the [Rising Waveform] and [Falling Waveform] keywords a variety of load circuits may be used, depending on the technology of the buffer. By selecting the proper load(s) and termination voltage(s), the turn-on time, turn-off time (and overlap between the two) of the pullup and pulldown stages of the buffer can be isolated in simulation and a more accurate behavioral model constructed.

A few recommended loads and waveforms are listed in Table 3.1 below.

Technology	# of Waveforms	Load Circuit and Waveform	Notes
Standard Push/Pull – CMOS	4	1R + 1F driving 50 Ω to Vcc 1R + 1F driving 50 Ω to GND	1
Open-drain/collector– CMOS, TTL and GTL	2	1R + 1F into manufacturer’s suggested pullup resistor termination and voltage	1, 2
Open-source/emitter – CMOS and TTL	2	1R + 1F into manufacturer’s suggested pulldown resistor termination and voltage	1, 2
ECL	2	1R + 1F into manufacturer’s suggested pulldown resistor termination and voltage	3

1. 1R = one rising waveform, 1F = one falling waveform
2. If termination resistor is > 100 ohms, include 1R +1F driving 50 ohms to termination voltage
3. A load of 50 ohms to a voltage of Vcc – 2 is a fixture typically recommended by manufacturers

Table 3.1 – Recommended Load Circuits and Waveforms for V-T Data Extraction

Note:

Be aware that not all EDA tool vendors’ simulation software may use all the V-T tables provided in the model. If in doubt, check with your EDA tool vendor.

In many cases, particularly for buffers with fast output transitions, the most appropriate load is a resistive value corresponding to the impedance of the system transmission lines the buffer will drive. For example, a buffer intended for use in a 60 Ω system may best be modeled using a 60 Ω load (R_fixture).

While supported by the IBIS version 2.1 specification and later versions, the use of reactive elements as V-T table loads is not recommended. A resistive load should be used wherever possible.

As with the simulations for ramp rate, the slew rate of the internal driving waveform should be appropriate to the normal use of the device. For meaningful results, all of the above rising and falling waveforms should be taken with the package parameters (R_pin, L_pin and C_pin or R_pkg, L_pkg and C_pkg) and fixture reactive elements (L_fixture and C_fixture) set to zero. As noted in the IBIS specification, all rising and falling waveforms should be time-correlated. In other words, the data in each of the rising edge waveform tables must be entered with respect to a common reference time point on the input waveform used to stimulate the buffer. The data in each of the falling edge waveforms must be time-correlated in a similar manner.

Finally, some buffers may show slightly different rising and falling edge characteristics depending on how much time the buffer has had to settle from a previous output transition. Some projects may ask that the model creator extract ramp or V-T data from the second or third output transition in a series. Note, however, that all V-T table data should be extracted over a duration long enough to ensure steady-state DC behavior at the start and at the end of the data set. In some cases, this may require simulating buffer performance for a significant period before collecting transition data, in order to ensure any logic associated with the driver is in a known DC state.

3.2.3 Minimum Time Step

As a rule of thumb, set the minimum time step to maximize the number of data points in the rising and falling V-T tables within the limits of the IBIS specification. The V-T waveform tables can contain no more than 100 points under IBIS version 3.2. IBIS version 4.0 permits up to 1000 points per V-T table).

3.2.4 Multi-Stage Drivers

Some buffer designs involve staged activation of the buffer as a function of time. For these buffers, a single set of V-T and I-V tables may only correctly describe one of the stages through which the buffer passes in any one transition. In this case, the [Driver Schedule] keyword may be used to combine several sets of V-T and I-V tables as a function of time. See *Advanced Keywords and Constructs* below.

3.3 Extracting Buffer Capacitance (C_comp)

The C_comp parameter specifies the buffer's capacitance and can have a typical, minimum and maximum value. C_comp represents only the capacitance of the transistors, die pad and on-die interconnect for an individual buffer. It does not include package capacitance.

C_comp may be generated using one of four methods:

- performing an AC or frequency sweep analysis of the buffer
- placing a resistive load at the output and calculating the RC charge or discharge time
- driving the pad using a transient voltage source and dividing the source current by the dV/dt
- placing a resistive and inductive load at the output to form a "tank" or resonant circuit with C_comp, and finding the resonant frequency

One way C_comp can be measured for a single-ended buffer is by connecting an AC voltage source to its I/O pad and reading the imaginary part of the current in that AC source, as shown in the figure below.

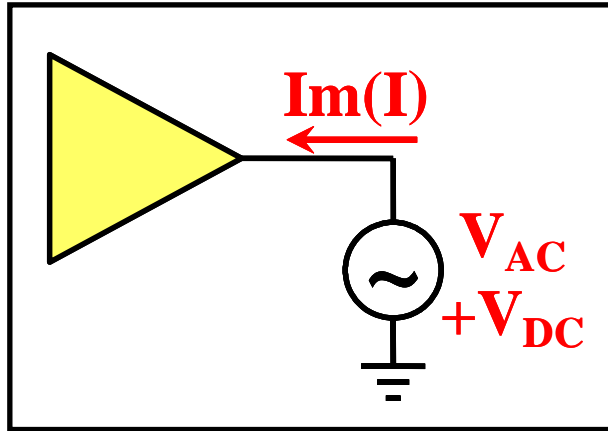

Figure 3.3 – Fixture for Extraction of C_comp Information

The capacitance can be calculated using the following formula:

$$C_{comp} = -Im(I_{AC}) / (2 * \pi * f * V_{AC}),$$

where $Im(I_{AC})$ is the imaginary part of the current measured through the AC voltage source, f is the frequency of the AC source and V_{AC} is the AC amplitude of the AC source. Please note that, for IBIS, the polarity is positive when the current flows into the part. Since we are interested in the current flowing into the buffer while measuring it in the AC source, the polarity of the current reading will have to be inverted. Therefore, a negative sign is used in the above equation. If the capacitance of the buffer is affected by the DC voltage on the output pad (bias), one must also set the DC offset in the AC source to an appropriate value. Since the capacitance of most buffers usually varies with frequency as well as voltage, it is advisable to run a series of simulations in which both of these parameters are swept over a certain range. The results of such simulations can be displayed on a surface plot, as shown in Figure 3.4 below.

Using a resonant or “tank” circuit to find an appropriate C_{comp} value is documented in a presentation by Hazem Hegazy:

<http://www.eda.org/ibis/summits/jun02/hegazy.pdf>

For any method of extraction, the C_{comp} value used in the IBIS model should correspond to the most likely operating frequency and bias voltage of the buffer.

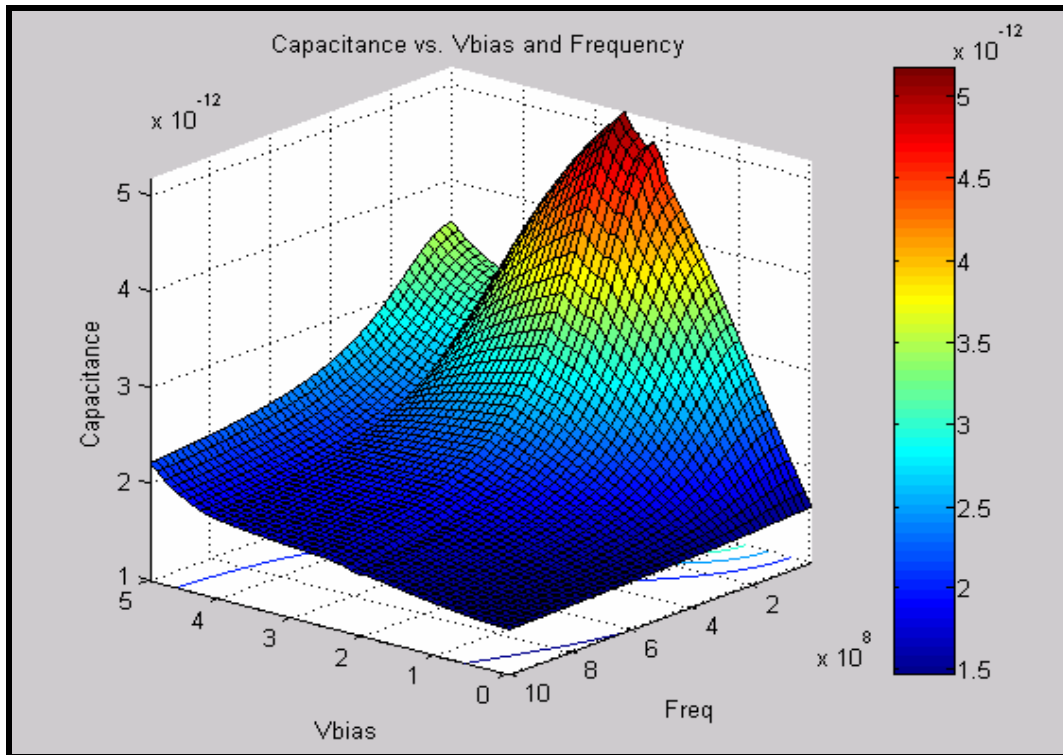

Figure 3.4 – Surface Plot of Buffer Capacitance versus Frequency and DC Bias Voltage

3.3.1 C_comp_pullup, C_comp_pulldown, C_comp_power_clamp, and C_comp_gnd_clamp

The IBIS version 4.0 specification introduced four additional C_comp subparameters, C_comp_pullup, C_comp_pulldown, C_comp_power_clamp, and C_comp_gnd_clamp. These subparameters define the capacitance which can be measured between the I/O pad and any of the four supply references, [Pullup Reference], [Pulldown Reference], [POWER Clamp Reference], and [GND Clamp Reference]. Breaking up the single C_comp into these portions is very important for power delivery network analysis.

The circuit for measuring split C_comp values is very similar to that used for the basic C_comp simulation, except the current will be measured at the supply connections, instead of the I/O pad.

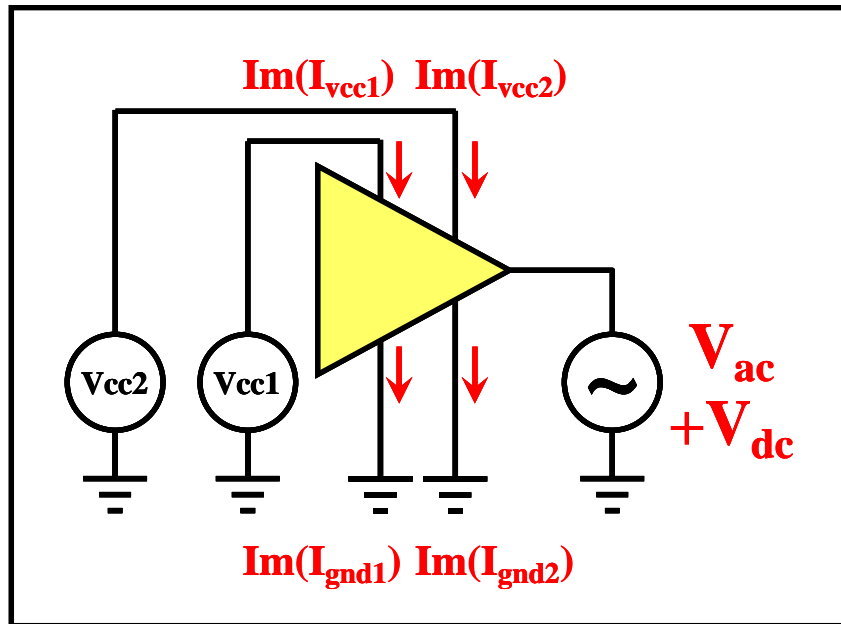

Figure 3.5 – Fixture for Extraction of C_comp Information

The four capacitance values can be calculated with the same formula as shown earlier.

Please note that the four supply connections will not necessarily be available for all buffer designs. For this reason, the IBIS specification does not require any of these split (partial) C_comp parameters, and the model maker should only use as many of them as necessary.

3.4 Obtaining I-V and Switching Information via Lab Measurement

You can obtain I-V tables and rise/fall time information from the actual buffer, using the following lab setup:

- A programmable power supply with an output capable of sinking and sourcing current while maintaining the required output voltage. The output must be floating.
- A curve tracer
- A digital sampling oscilloscope with an appropriate bandwidth
- A low capacitance probe (e.g., a FET probe)
- A test fixture used for I-V table measurements
- A motherboard or specific test fixture used for V-T table measurements
- If available, a thermoelectronic plate, peltier device or other equipment to control die temperature

To obtain I-V table measurements, mount the component to be tested in the I-V test fixture and connect the power and ground pins of the DUT to the programmable power supply. Attach the hot/cold plate to the component with a very thin layer of thermal grease and adjust the temperature as desired. Wait for the die to stabilize at the desired temperature. Select an output on the DUT in the desired state (high or low) and use the curve tracer to obtain the I-V characteristics of the output.

Note

During curve tracing of a 3-statable output, the table contains both the transistor and the diode output characteristics. To obtain tables for the diodes alone, select and curve

trace the output in its high impedance state. Buffers containing time-delayed feedback can produce bad results.

Reference the pullup and power clamp data to V_{cc} , as described in the IBIS specification. You can obtain this data directly by connecting the curve tracer's negative (reference) lead to the V_{cc} supply of the DUT, then setting the curve tracer for a negative sweep. Make sure no ground path connects back through the AC line between the component ground and power supply ground. For standard pulldown and clamp diode tables, attach the negative lead to the DUT's GND supply and use a positive sweep direction. For V_{cc} -relative measurements, ensure the supply is floating.

Note that package and on-die parasitics, particularly resistive effects, can distort the I-V measurement data taken at pins relative to the behavior at the die pads expressed in IBIS models. Ensure that any voltage sweeps are performed as slowly as necessary to avoid distortions from reactive elements. Obtain an estimate of the package resistivity and consider this when obtaining the I-V data.

Similarly, thermal measurement at the package surface may not be reflective of at-die conditions.

The curve tracer may not be able to sweep the entire range required by the IBIS specification. In this case, the model creator must extrapolate the tables to the required range.

Capturing rise/fall time data requires either a specific test fixture or a motherboard to which the DUT can be attached. Depending on the driver's edge rate, rise/fall time measurements may require an oscilloscope with a wide bandwidth. As with the I-V measurements, V-T data must not include package information when eventually included in the final IBIS file. Take into account the effect on the rise/fall times of the packaging, interconnect and any loading by the fixture. Use a probe with extremely low loading, such as a FET probe. The probe grounding should be as short as possible.

Using the oscilloscope, capture data for the buffer driving a known load. Then, using the known packaging parameters and measured I-V tables, construct a simulation model of the buffer using an initial estimate of the rise/fall time. With an IBIS simulator, adjust the rise/fall times in the model until the simulation results match the oscilloscope waveforms. For greater accuracy, lift the pin under test from the board to remove any load other than the oscilloscope probe. Simulate with a package and probe model to match this captured waveform data.

4.0 Extracting the Data – Differential Buffers

4.1 Introduction

Today’s high-speed designs make increasing use of various kinds of differential buffers and signaling techniques. Unfortunately, the related terminology is not always defined unambiguously. Therefore, this chapter will begin with a short overview of the fundamental concepts of differential and single-ended signaling, and the basic operation of differential drivers and receivers. These principles are essential to understanding the process for extracting data from differential buffer designs for IBIS.

The main difference between differential and single-ended signaling is very closely related to how voltages and/or currents are observed by the receiver and/or generated by the driver. From basic physics, a voltage can only be measured between two points (there is no such thing as a voltage of a single point). Similarly, current makes only sense when we talk about a path (or branch), through which current can flow. Since a current path is an electrical connection between two points, a relationship between voltage and current can be easily established. From this perspective, all voltage and current measurements or observations are differential in nature, because they involve a relationship between two distinct points in space. These principles are valid regardless of whether the voltages and currents we are observing represent signals or power.

The simplest circuit, having an input, output and power supply port, will need six terminals if each of these ports are to be kept independent (or isolated) from each other for analysis purposes. However, the usage of a common reference can reduce the total number of terminals to just four. In practical designs, such simplifications can provide significant cost savings and reduction of complexity, especially on large designs. Whether or not such simplifications can be done depends on many different requirements, such as safety, cost, and performance, just to name a few.

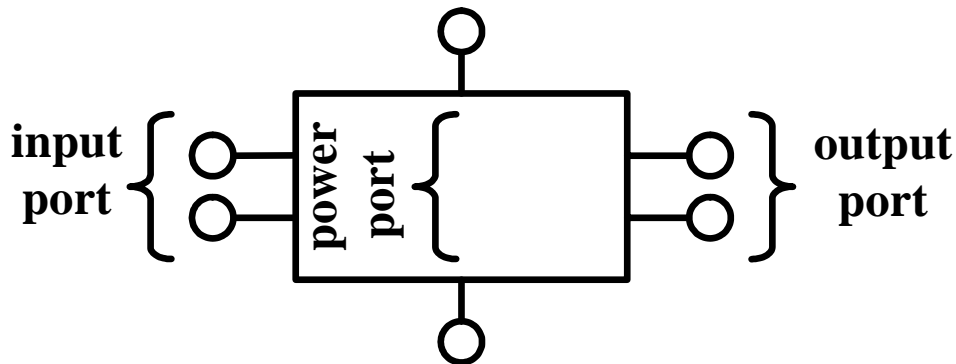

Figure 4.1 – Device with Independent Input, Output and Power Supply Ports

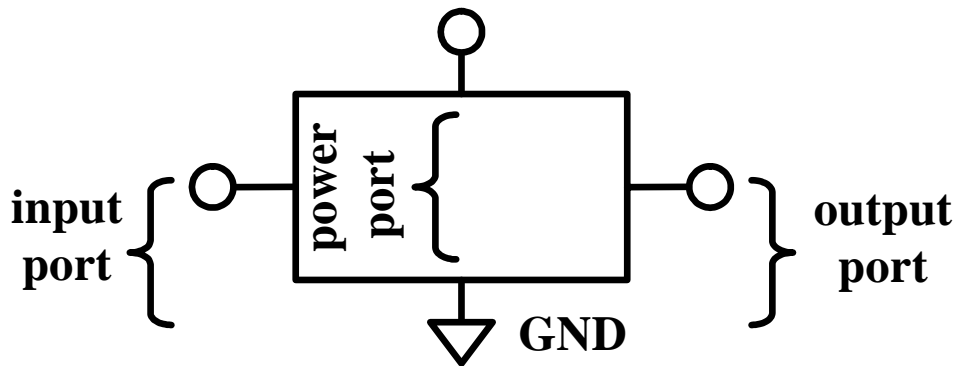

Figure 4.2 – Device with Ports Using Common Ground

The determining factor between differential and single-ended systems is the referencing scheme. When studying a transmission line, we need to find out whether its reference is a power or ground plane, or another “signal” trace. A single-ended transmission line has only one signal trace whose reference is some sort of a power or ground plane that is common to the entire design. A differential transmission line has “two signal traces”, either one of which can be considered as the reference of the other. When studying a buffer, we need to ask, “What are the two terminals of the input or output port?” A differential buffer’s input or output port consists of two dedicated terminals. Neither of these terminals is common with the power or ground terminals. On the other hand, a single-ended buffer’s input or output port consists of only one dedicated terminal. The other terminal is shared with either the power or ground terminal.

In summary, we can think of a differential signal as information sent with its own reference. A single-ended signal, on the other hand, does not include a reference because it is assumed available either as a common power or ground connection, or as a locally generated reference derived from a common power or ground connection. The following figure illustrates an input port with a locally generated reference.

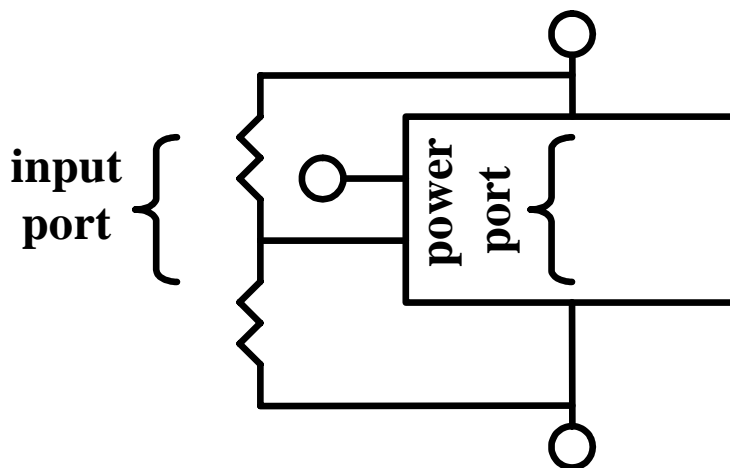

Figure 4.3 – Input Port with Locally Generated Reference

Using the above criteria of referencing, there are two major categories for signaling schemes: differential and single-ended. However, from a buffer designer’s perspective we can actually define three categories. In this document we will refer to these as fully differential, half-differential, and single-ended (pseudo-differential) drivers and receivers. Each of these is reviewed below.

Note that the terms “fully differential,” “half-differential” and “pseudo-differential,” as used below, refer to the *design* or *structure* of the buffer: the current relationship between its pads and the degree of isolation of its output from its supply rails. The IBIS specification, particularly IBIS version 4.1, refers to “true” and “pseudo-differential” buffers in terms of how they are *represented* using IBIS keywords, subparameters and concepts. As will be shown, a particular IBIS representation may be used for several different types of buffer structure (for example, a “pseudo-differential” approach under IBIS – using complementary single-ended buffers and the [Diff Pin] keyword – may adequately represent the behavior of many half-differential buffer designs). In the case of data collection in the lab, the actual buffer structure may not be known and therefore may not determine the IBIS representation used.

4.2 Differential Receivers

In order to appreciate the operation of differential receivers, single-ended receivers must be understood. A single-ended receiver is usually implemented as transistors connected between the input and ground and/or between the input and power supply terminals. If the receiver is built using field effect transistors (FET), the transistor will usually detect the signal as a voltage that is observed between the input terminal and the power and/or ground supply rails. If the receiver is built with bipolar junction transistors (BJT), the transistor will usually detect the signal as a current flow between the input terminal and the ground and/or power supply rails. In short, the input signal is evaluated with respect to one or both of the supply rails. Figure 4.4 below illustrates a simple receiver using CMOS technology.

Please be aware, that the schematics used as illustrations below are provided only to give a better understanding of the discussion at hand. The examples are not intended to be exhaustive in covering the vast abundance of possible circuit designs and configurations.

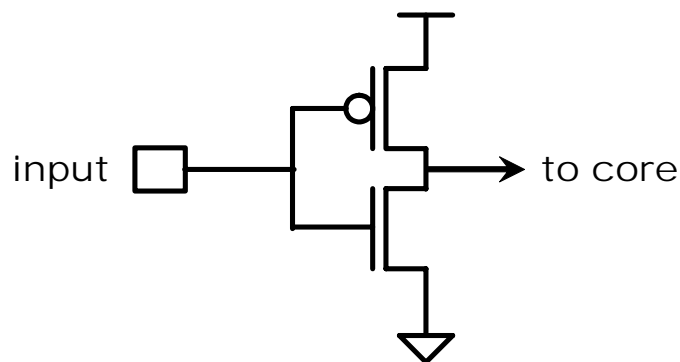

Figure 4.4 – Single-ended Receiver

The most obvious difference between a single-ended and differential receiver is that the differential receiver has two input terminals as opposed to one. The transistors of a fully differential receiver are usually arranged so that they are isolated from both the power and ground supply rails by high impedance circuit elements. This allows the receiver to operate independently from the power and ground supply rails (within the limits of the current sources providing the isolation), resulting in good power supply noise immunity. Therefore, the incoming signal is evaluated solely as a voltage difference or current flow between the two input terminals. This construction provides an additional useful feature for the differential receivers, which is the so-called common mode rejection ratio (CMRR). Such a receiver implementation is shown in the figure below, which is built using two input transistors, a constant current source and a current mirror.

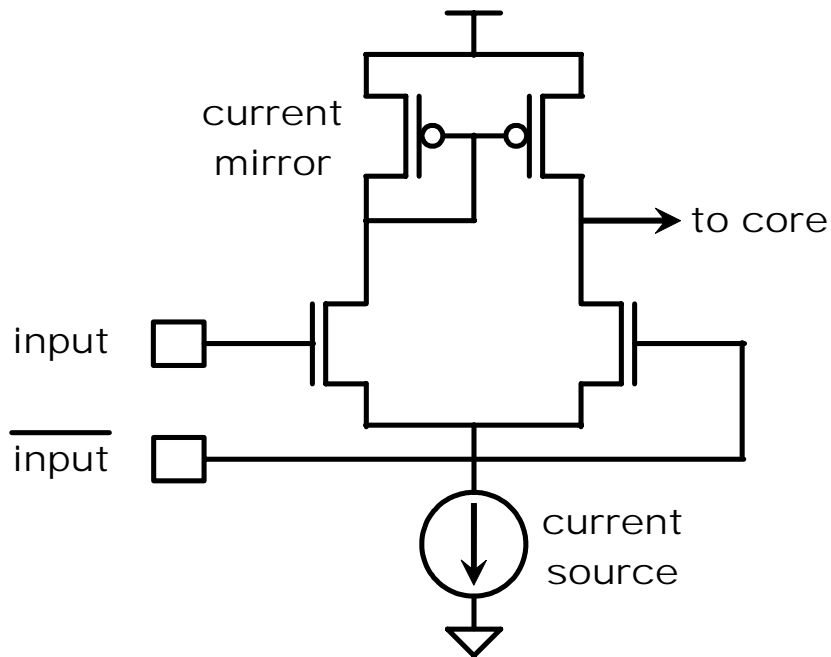

Figure 4.5 – Fully Differential Receiver

Half-differential receivers are similar in construction, except that the receiver's input transistors are isolated only from one of the two supply rails by a high impedance path. Depending on the circuit topology, these types of receivers will still evaluate the signal as a voltage difference or current flow between the two input terminals, but the power or ground noise immunity and the CMRR characteristics of such receivers may be inferior to the fully differential receivers due to the low impedance path to one of the supply rails.

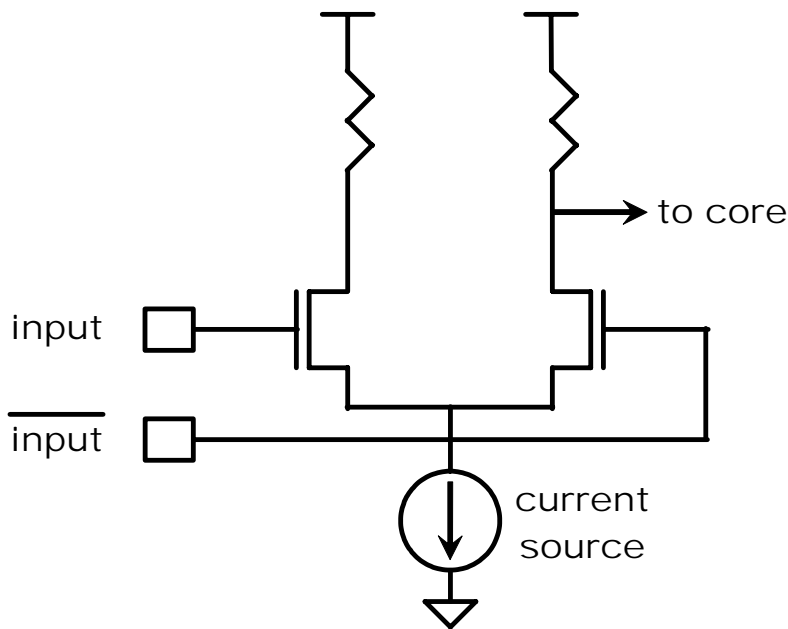

Figure 4.6 – Half-differential Receiver

Pseudo-differential receivers usually consist of nothing more than a single-ended receiver connected to each of the two input terminals. The signal on each input terminal is evaluated with respect to the power and/or ground supply rail, and the “difference” signal is obtained by evaluating the logic states of the two independent single-ended receivers. This configuration has no supply rail noise immunity or *analog* common mode signal rejection capability whatsoever.

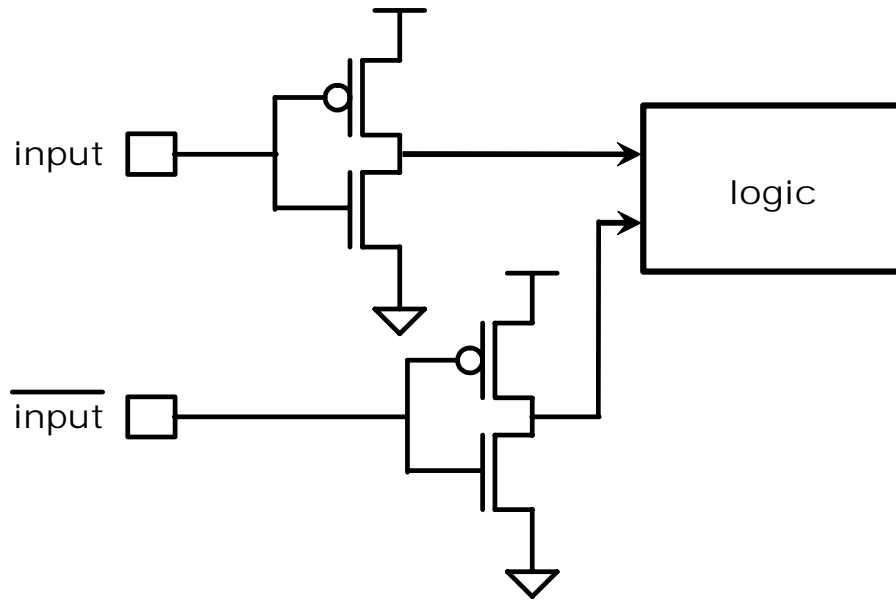

Figure 4.7 – Pseudo-differential Receiver

4.3 Differential Drivers

In order to appreciate the operation of differential drivers, it is useful to understand how single-ended drivers work. A single-ended driver is usually implemented as transistors connected between the output and ground and/or between the output and power supply terminals. When the driver is driving low, the transistor between the output and ground terminals will be turned on, providing a low impedance path from the output terminal to ground. When the driver is driving high, the transistor between the output and power terminals will be turned on, providing a low impedance path from the output terminal to the power supply rail. In other words, a path is established for current flow between the output terminal and one or the other power supply rails, and if there is a current flow, a voltage will appear on the output terminal with respect to the corresponding supply rail. The following figure illustrates a simple driver using CMOS technology.

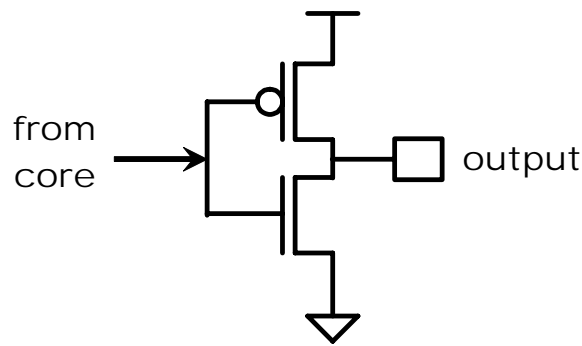

Figure 4.8 – Single-ended Driver

The most obvious difference between a single-ended and differential driver is that the differential driver has two output terminals as opposed to one. The transistors of a fully differential driver are usually arranged so that they are isolated from both the power and ground supply rails by a high impedance path (usually a constant current source). This allows the driver to operate independently from the power and ground supply rails (within the limits of the current sources providing the isolation), resulting in good power supply noise immunity. However, there is a major difference between how single-ended and differential drivers generate the signal on their outputs. For the discussion that follows, please consider Figure 4.9 below.

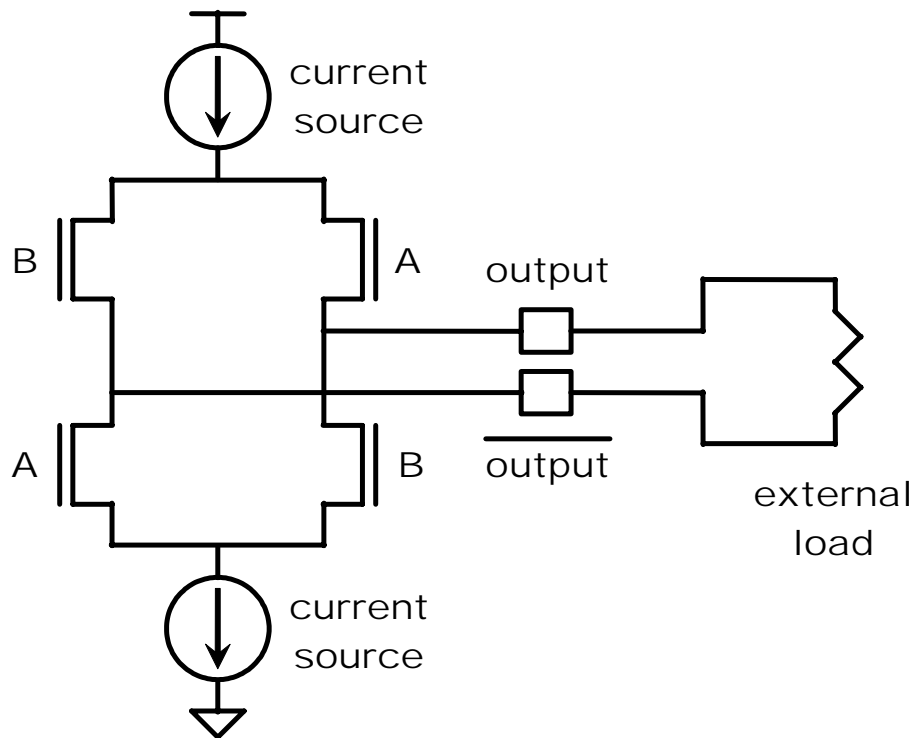

Figure 4.9 – Fully Differential Driver with External Load

In normal operation, the two current sources are designed so that they provide the same amount of constant current. When transistors “A” are turned on, transistors “B” are turned off or vice versa. When transistors “A” are on, the current from the power supply will exit at the non-inverting output terminal (output), and enter back in at the inverting output terminal (/output) through the external load resistor and will continue down through

the second “A” transistor to the ground rail through the current source on the bottom. When transistors “A” are off and “B” are on, the direction of the current flow is reversed between the two output terminals, and the current will exit at the inverting terminal (/output) and enter at the non-inverting terminal (output). This implies that the signaling of a fully differential buffer is established by controlling the direction of the current flow between the two output terminals through the purely differential load placed between them. The amount of output current is independent of the supply voltage (within the normal operation of the current sources). This provides the good power and ground noise immunity. The voltage level of the signal is determined by the output current and the load impedance. Please note that with a purely differential load, providing a current path only between the two output terminals, a voltage will only be measurable between the two output terminals, as the signal will be truly floating with respect to power and/or ground.

Half-differential drivers are similar in construction, except that the driver’s output transistors are isolated only from one of the two power supply rails by one current source only. Half of the circuit (two switching transistors and a current source) is usually replaced by two resistors (or equivalent). These resistors are connected to the same supply rail from which the current source was removed. Since these two resistors introduce a low impedance path to one of the supply rails, the power or ground noise immunity of such drivers may be inferior as compared with fully differential drivers. Please refer to Figure 4.10 below for an illustration of a half-differential driver.

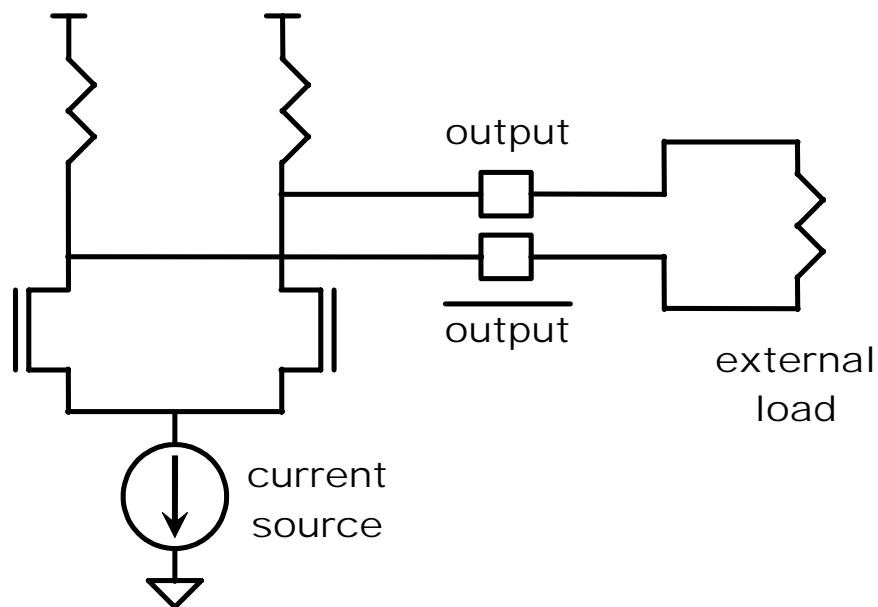

Figure 4.10 – Half-differential Driver with External Load

Pseudo-differential drivers usually consist of nothing more than two single-ended drivers connected to the two output terminals, driven in the opposite direction. The signal on each output terminal is generated as a result of the low impedance path found between the output terminals and the power and/or ground rails. A “differential current” between the output terminals will arise when there is a (differential) load between the two outputs. This current, however, is essentially the result of a voltage divider circuit found between the two power supply rails, and therefore highly influenced by the power supply noise.

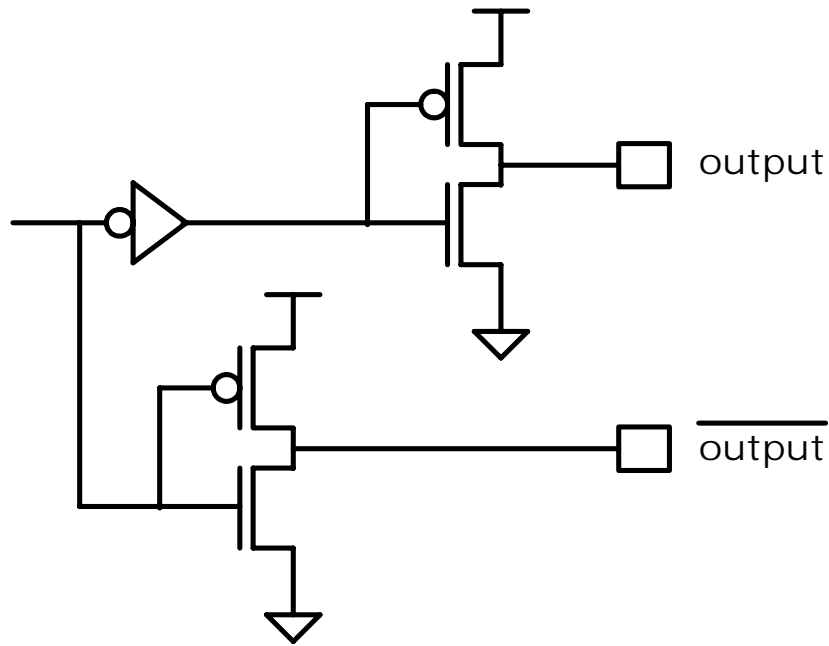

Figure 4.11 – Pseudo-differential Driver Example

4.4 On-die Termination

In addition to the circuit elements forming the basic driver and/or receiver circuits discussed above, we may sometimes find additional elements, most often serving the purpose of on-die termination schemes. In general, termination circuits can be grouped into three categories. They can be implemented as pure differential, common mode only, or full termination (π structure or T structure). Please note that the choice of termination style may be independent from the choice of driver and/or receiver style, and they could be mixed. For example, a fully differential receiver may have common mode only terminators, or a pseudo-differential driver may have a pure differential on-die termination, etc...

A pure differential termination consists of a resistor (or equivalent) connected between the two signal terminals. A common mode only termination consists of resistors (or equivalents) connected between the signal and the power supply or ground terminals. The full termination (π structure or T structure) is a combination of the previous two, using a total of three resistors (or equivalents). As their name indicates it, these termination styles will terminate the transmission lines connected to the signal terminals in the differential mode, common mode, or both modes, respectively.

It should be noted that in the case of half or pseudo-differential drivers, the driver design itself may contain circuit elements (resistors or equivalents) which act as termination devices. Since these are usually connected to one or the other power supply rail, these circuit elements usually provide termination only for the common mode components of the signal (or noise).

Another reason fully differential drivers and/or receivers may have additional circuit elements connected to the signal terminals is to prevent the signal lines from floating freely. This is usually implemented as weak (high impedance) bias generator circuits and/or resistor (or equivalent) networks using high resistance values.

Please note that even though differential receivers have two input terminals, there are designs in which only one of these terminals are brought out to the pad or the package pin or ball of the product. In these situations, the second input terminal is usually connected to an internal reference generator. In addition, even if both of the input terminals are brought out to the package pin or ball of the device, some signaling specifications define a single-ended signaling with an externally generated reference to be connected to the second input terminal of the differential receiver. A variant of this technique comprises a group of receivers sharing a common reference input to reduce the total number of package pins or balls on the product.

4.5 Differential Buffer Modeling with IBIS

When discussing differential signaling, differential transmission lines, or termination schemes, experienced engineers usually have a good understanding of the terms “common mode” and “differential mode”. The same principles can be applied to differential buffers also. This concept is especially important when we make IBIS models for differential buffers because of the peculiarities of the IBIS specification.

The IBIS specification has a simple mechanism for modeling differential buffers. The [Diff Pin] keyword is provided to allow the model maker to associate two [Model]s as a differential pair. Since the [Model] keyword was designed to model single-ended buffers only, strictly speaking, this mechanism is only useful to model pseudo-differential drivers and receivers. As discussed in the above sections, pseudo-differential models can only describe the electrical relationships between the signal and power supply terminals, and are unable to include any information on what happens between the two signal terminals of a differential buffer.

Fortunately, there are other mechanisms in the IBIS version 4.0 specification that may be used to overcome this limitation. First, we should note that the [Model] keyword has a Model_type subparameter that can be set to “Series” to model series structures found between signal pins. The original purpose for the series model type was to allow the modeling of devices that are in series with a signal path, hence the name “Series”. The “Series” type is also particularly useful for modeling elements placed between the terminals of differential buffers.

A [Model] of type “Series” can contain a number of keywords which may be used to describe passive circuits containing various combinations of inductors, resistors and capacitors, as well as the steady state I-V characteristics of non-linear, active devices, such as transistors. A [Model] of type series can be mapped between any two pins listed under the [Pin] keyword using the [Series Pin Mapping] keyword. It is important to note that the IBIS specification does not impose any limitations on the type of pins the [Series Pin Mapping] keyword can reference, and there are no limitations on how many series models can be connected to a single pin. In practical terms this means that a series model can be mapped between any arbitrary combination of POWER, GND, NC, or signal pins, and that a single pin may have multiple series models connected to it, including another [Model] which describes a normal I/O buffer, for example. Considering these aspects of the IBIS specification, we can construct a model for a differential buffer as shown in Figure 4.12 below.

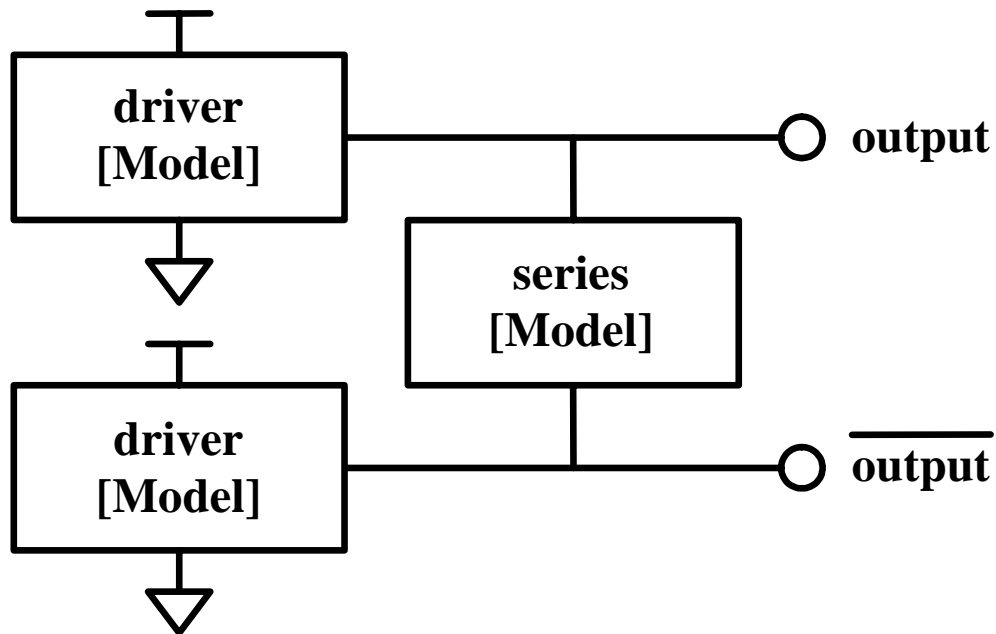

Figure 4.12 – Block Diagram of a Fully Differential Model using IBIS Version 3.2 Constructs

The three boxes in this schematic illustrate how the common and differential mode characteristics of a differential buffer can be modeled with IBIS constructs. This arrangement can be applied to fully differential, half-differential, and pseudo-differential buffers equally well. (In the case of the pseudo-differential buffers, the box labeled “series [Model]” would not be needed). However, there are a couple of important limitations involved in using this concept.

First, even though [Model]s of type series can describe passive and active circuit elements, the IBIS specification does not provide any control signals for them. This means that a series model cannot be turned on or off, it is considered to be in a static condition throughout the entire simulation. The associated [On] and [Off] keywords provide only a static selection mechanism which cannot be changed during a simulation. For this reason, we can only model differential drivers that have static differential characteristics, i.e., the series [Model] can only contain I-V tables but no V-T tables. As we will see it later in this chapter, this does not seem to be a serious limitation in most practical situations, but in case we need to model dynamic differential characteristics in a buffer, we can make use of the capabilities introduced in the external language extensions of the IBIS version 4.1 specification.

Second, even though models generated with this technique can reproduce the waveforms at the I/O terminals accurately, the currents observed at the supply terminals may not accurately represent the corresponding currents of the actual design. For this reason, these models may not be suitable for power and/or ground noise analysis using a non-ideal power supply network.

Please note that due to the lack of a better term, in the remaining part of this chapter we will refer to the two boxes labeled “driver [Model]” as the common mode model, even though a deeper analysis of these models would reveal that this terminology is not entirely correct.

4.6 Data Extraction

Now that we have a high-level concept for modeling the common and differential characteristics of differential buffers, let us discuss how the data can be extracted from a SPICE model for each of these building blocks. Even though in many cases the IBIS model maker does have access to the SPICE netlist, and could extract the data for the above IBIS constructs using different techniques, the preferred method for the data extraction process is one that does not require any editing of the SPICE netlist. In more complicated designs, it may be difficult to find clear boundaries for the common and differential mode characteristics in the netlist. It turns out that a simple numerical decomposition technique is available to provide the appropriate data for each building block. Unfortunately, at the time of this writing, the process described in the following sections has not been automated yet; therefore, most of these steps will have to be done manually. However, a presentation on the following discussion including some code examples is available at:

<http://www.eda.org/pub/ibis/summits/oct03/muranyi.pdf>

4.6.1 Extracting Common Mode I-V Tables

To simplify the text, we will discuss a differential driver in the following section. Everything here will also apply to differential receivers, unless otherwise noted. The I-V table of a driver is usually measured by forcing a voltage on the output of the buffer and measuring the output current while keeping the buffer in the same logic state. However, since we are dealing with a differential driver, we must ask the question: “Which voltage are we talking about, common mode or differential mode?” The correct answer to this question is, “both”. The added complexity with differential buffers is that the measured current on one of the output terminals may not only depend on the voltage between that terminal and the ground (or power) supply rail (common mode voltage), but it may also depend on the voltage on the other output terminal (differential mode voltage). For this reason, a 2-dimensional I-V table is not sufficient to describe the I-V characteristics of a differential buffer. To describe the current (the dependent variable) as a function of two voltages (the independent variables) we must use a 3-dimensional surface plot.

An I-V surface plot can be generated by connecting two voltage sources to the output terminals of a differential port as illustrated in the following figure. The voltage sources are swept through the necessary voltage range in a nested loop fashion so that a current reading is obtained for all possible voltage combinations. We can actually generate two I-V surfaces with this arrangement, with the current reading obtained from each of the output terminals. Due to the complementary nature of the outputs, one of the surface plots will correspond to the logic “1” state of the buffer, and the other will correspond to the logic “0” state. For receivers, the surface plots will contain only clamping and/or on-die termination currents. Unless the receiver has asymmetric characteristics, the measurements obtained from the two terminals will be identical.

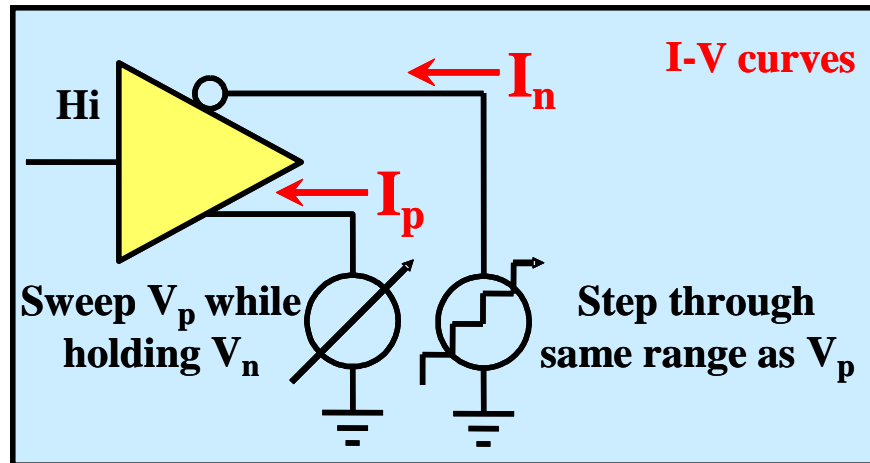

Figure 4.13 – I-V Table Extraction Fixture for a Differential Buffer

The raw data of such an I-V surface sweep is shown in the following figure.

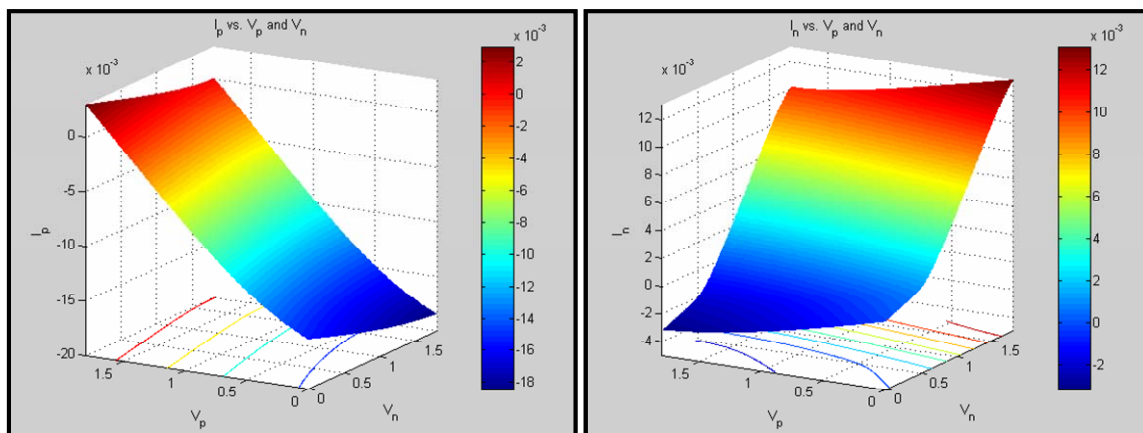

Figure 4.14 – Surface Plots of Raw Data from I-V Sweep of Differential Buffer

The data shown in these plots, being the total current at each output terminal, represents the sum of the common and differential mode currents inside the buffer. Both of these surface plots contain the same exact amount of differential current, because the differential current that flows between the two output terminals is the same regardless of the terminal from which we observe it.

Our next task will be the separation of the common and differential mode currents, to be used in the corresponding [Model]s. In order to do this, we assume that the internal differential current is zero when the differential voltage is zero. While this assumption is true for a resistive path, can it be applied when there are reactive parasitics inside the buffer, such as a capacitor? The answer is a yes, with the condition that we perform a relatively slow sweep during the I-V surface data generation process. A slow voltage sweep corresponds to a low dV/dt , which in turn minimizes the (error) current due to the reactive parasitics. The error or the sweep speed requirements can be calculated from the basic time domain capacitor equation:

$$I = C \cdot dV/dt$$

For example, a 1 pF parasitic capacitance will yield 1 μA of error in our current readings if we sweep the voltage at a 1 V/ms rate. Having said this, we can conclude that the internal differential current is negligible along the equipotential diagonals in the raw data shown above, which also implies that the current reading along these diagonals must be solely due to the common mode characteristics of the driver. Therefore, extracting the current along these yields two 2-dimensional I-V tables, which can be used to fill the [Pullup] and [Pulldown] tables of the common mode [Model]s. These I-V tables are illustrated in the Figure 4.15 below.

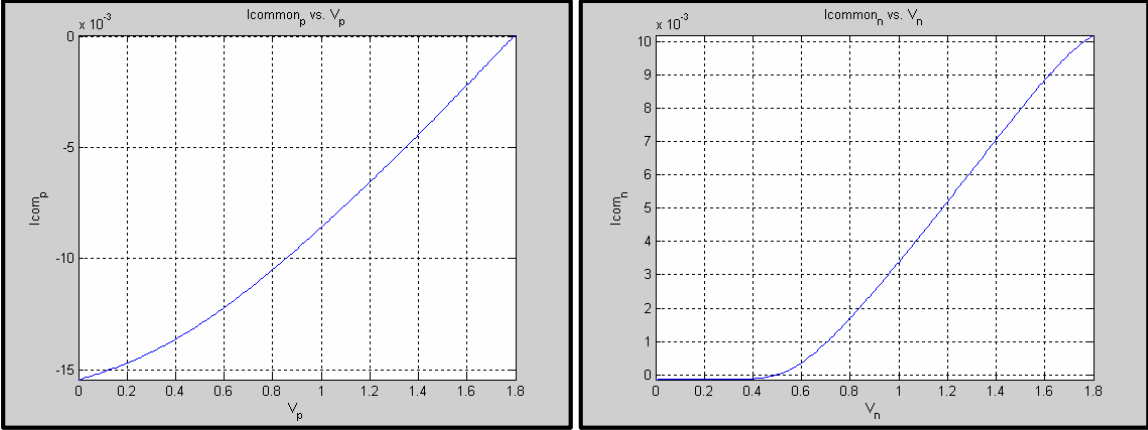

Figure 4.15 – I-V Curves of Common Mode Characteristics of Differential Buffer

4.6.2 Extracting the Differential Mode I-V Surfaces

Since the raw data obtained from the I-V sweep contains the sum of the common and differential mode currents, we need to find a way to extract the differential mode current to be used in the series [Model]. Based on the above discussion, we know that the equipotential diagonal of the surfaces contain nothing but the common mode current. In order to eliminate this common mode component, we just need to perform a vertical translation (shifting) of the surfaces so that their equipotential diagonal becomes zero. This process is similar to summation with a constant, except that the constant is changing for each row in the data matrix (corresponding to the value found in the diagonal for that row). The result of this operation is shown in the Figure 4.16 below.

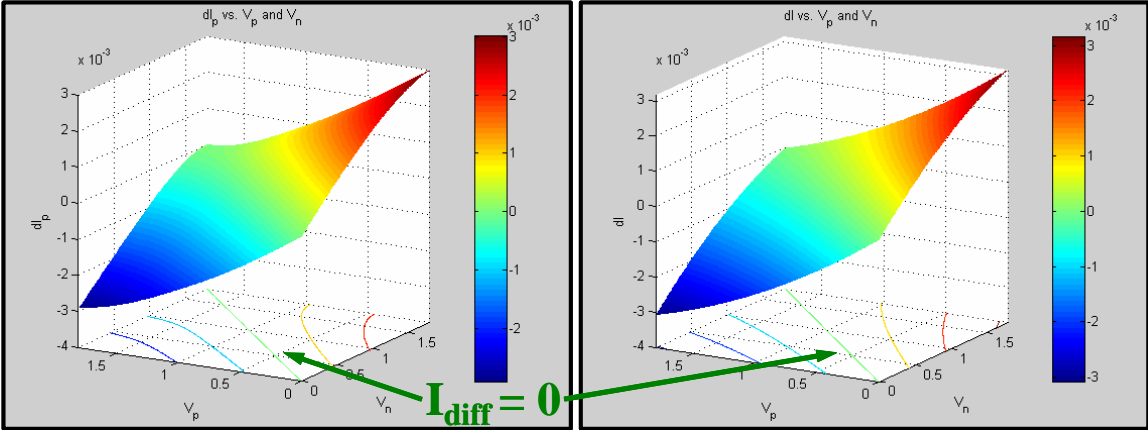

Figure 4.16 – Differential Current Plot of Output Current versus P and N Voltage

Notice that the two surfaces shown are identical, because they represent the same differential current flowing between the two output terminals. One of the surfaces shows the current as observed at one of the terminals, and the other surface shows the current as seen at the other terminal. Either one of these surfaces can be used as data for the series [Model], but in order to make this data IBIS-compliant, we will first need to reformat it.

If the surface plot represents the I-V relationship of a linear device, such as a resistor, its shape will be completely flat, with a slope perpendicular to the equipotential diagonal. In this case, we can represent the entire surface using a resistance equivalent to the numerical value of this slope. This equivalent resistance is placed between the two output terminals and can be easily modeled using the [R Series] keyword in the series [Model] (see *Advanced Keywords and Constructs* below).

If the surface plot exhibits non-linearities, we have two keyword options, depending on which way the non-linearities are oriented. If the non-linearity is only a function of the differential voltage, i.e., the curvature of the surface goes only in the direction of the diagonal that is perpendicular to the equipotential diagonal, then we can make use of the [Series Current] keyword in the series [Model] (see *Advanced Keywords and Constructs* below). To fill in the I-V table of this keyword, we just extract the current along this diagonal from the surface plot.

If the surface plot contains non-linearities including voltage dependencies that include common mode voltage, we will have to use the [Series MOSFET] keyword (see *Advanced Keywords and Constructs* below). The IBIS specification states that this keyword can have up to 100 I-V tables. These I-V tables correspond to 100 slices on the surface plot. The keyword also assumes voltage symmetry along the equipotential diagonal. The symmetry implies that the two halves of the surface are a mirror image of each other along the equipotential diagonal, and imposes certain limitations regarding the freedom in the shape of the surface. Figure 4.17 below shows an example in which the above surface was sliced to yield 18 I-V tables for the [Series MOSFET] keyword.

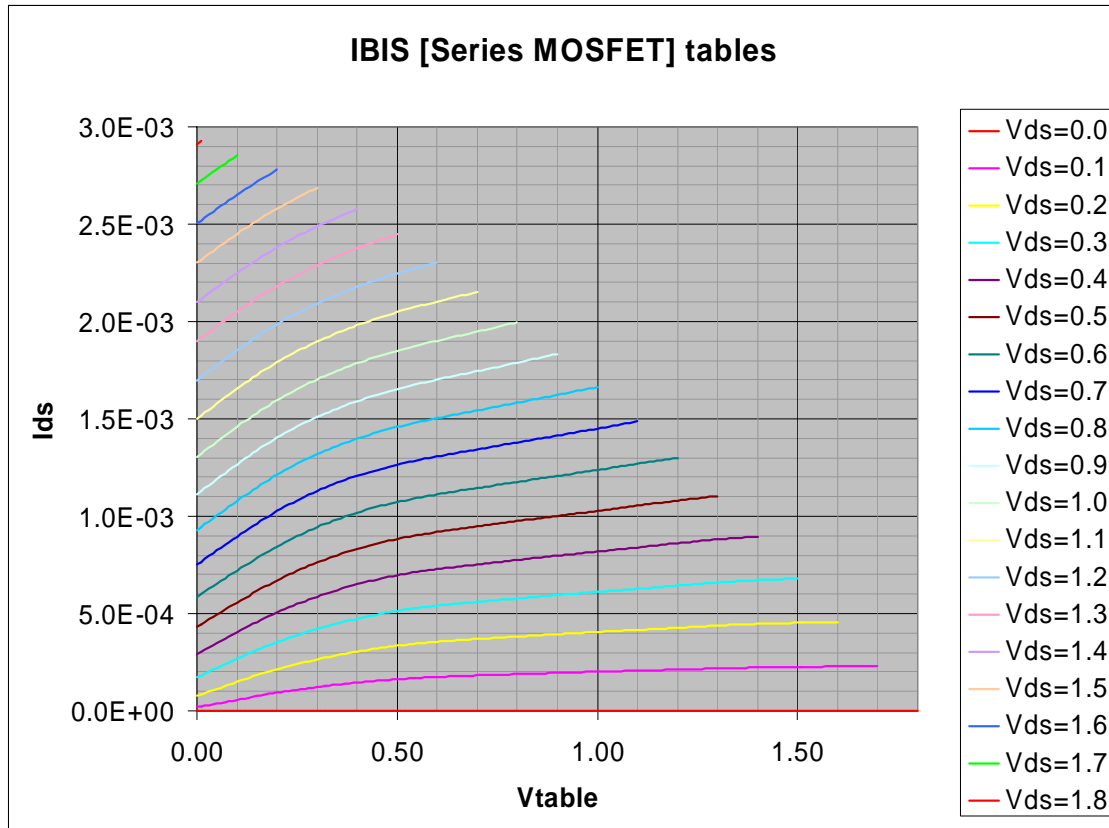

Figure 4.17 – Plots of Various Vds Values for a [Series MOSFET] Buffer

A tradeoff between accuracy and simplicity is also possible regarding the selection of the appropriate keyword for the series [Model]. One may choose to use the simple [R Series] keyword for the series [Model] if the non-linearities in the differential surface are negligible or insignificant. No universal recommendation can be made for the most appropriate technique to make a best-fit representation of the internal differential current surface. Sophisticated mathematical fitting algorithms are available to do this job, but a manual trial and error approach may also be possible.

4.6.3 Separating the On-die Termination I-V Tables

As it was shown above, half-differential drivers have two resistors (or equivalents) between one of the supply rails and the signal terminals. Since these resistors are never turned off, they can also be considered as common mode on-die terminators, and as such, their I-V characteristics should be placed into one of the clamp tables of the [Model]. Similarly, fully differential, or pseudo-differential buffers may also contain additional common mode on-die termination resistors (or equivalents), whose I-V tables should be placed into one of the clamp tables of the [Model]. As with normal single-ended [Model]s, care should be taken to avoid the duplication of these currents in the [Pullup] and [Pulldown] I-V tables.

The procedure for this is similar to the corresponding subtraction procedure used for single-ended drivers. The I-V characteristics of the driver must be obtained twice, once in the driving mode and once in the 3-stated (high impedance) mode, and the 3-stated I-V table data must be subtracted from the driving I-V table data. The only

added complexity in this procedure for differential drivers is that the subtraction is done after the common mode I-V tables have been extracted from the raw I-V surface data.

In addition, extra care should be taken to place the I-V characteristics of the on-die terminations into the appropriate clamp table. As with normal single-ended drivers and receivers, if the terminator is connected to the ground rail, its I-V data should go into the [GND Clamp] table, and if the terminator is connected to the power supply rail, its I-V data should go into the [POWER Clamp] table. In addition, the model maker must make sure that the termination's I-V data is not duplicated in both clamp tables. The procedure used for normal single-ended buffers applies to differential buffers also regarding the removal of this type of double counting.

4.6.4 Extracting V-T Table Data

First, the reader should understand that this section only applies to driver models since receivers usually do not have any switching characteristics. In addition, due to the series [Model] limitations in the IBIS specification, this modeling technique can only account for transient behaviors in the common mode model. Because of this, we will only need to generate V-T tables for the two common mode [Model]s that contain the common mode I-V table data.

The extraction of V-T table data follows the usual techniques applied to single-ended buffers. The outputs are connected to the familiar R_fixture and V_fixture load and the buffer is toggled to generate rising and falling waveforms. As usual, for R_fixture we should select a value that is close to the transmission line impedance (common mode) the buffer will drive, and for V_fixture we should use values that correspond to the upper and/or lower DC levels of the signal.

However, in addition to this arrangement, we will need to connect an additional current source between the two output terminals in order to generate correct V-T tables. The purpose of this source is to cancel any internal differential currents inside the SPICE model from which the V-T tables are generated. There are two reasons for having to do this. First, the V-T tables will be used in [Model]s that contain common mode I-V table data only. If the differential currents were not cancelled, we would get I-V and V-T mismatch warnings or errors from the IBIS file parser, because the DC levels of the V-T tables would not match the I-V table / R_fixture, V_fixture load line solution in the common mode [Model]. Second, the C_comp compensation algorithm in the [Model] only cancels the C_comp in the common mode model, which does not include the effects of the capacitance found between the two output pads (C_diff). If we did not cancel the effects of the differential current caused by C_diff in the V-T tables, the output waveform (i.e., edge rate) of the IBIS model would not be correct. Figure 4.18 illustrates this schematically.

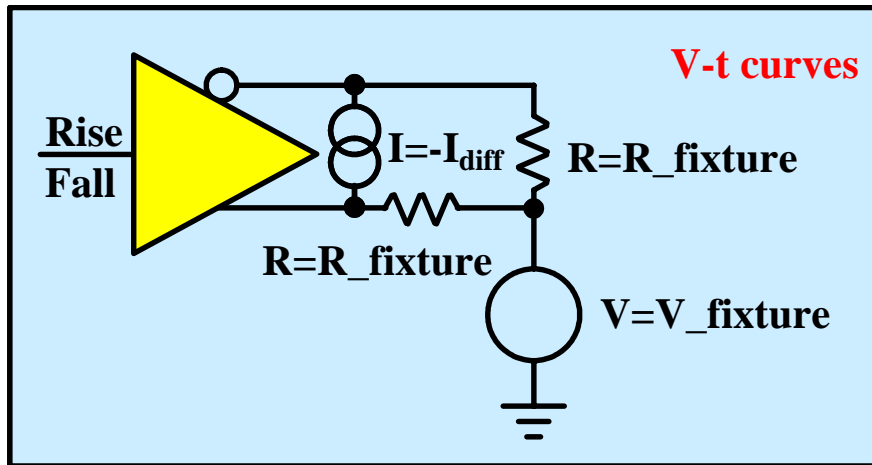

Figure 4.18 – V-T Table Extraction Fixture for a Differential Buffer

The cancellation current source can be implemented many different ways. The implementation may also depend on how the internal differential current is modeled in the series [Model]. In the simplest case, when the series [Model] contains an [R Series] and a [C Series] keyword, one can use the following HSPICE circuit to achieve the cancellation.

```

Eoutv      OutV      0          VOL= 'V(Out_p, Out_n)
C_diff     OutV      0          C= Value_of_C_diff
R_diff     OutV      0          R= Value_of_R_diff
Gcancel    Out_p     Out_n     CUR= 'I(Eoutv)'
```

The first line of this code is an ideal voltage source that creates a duplicate of the differential voltage found between the two outputs of the buffer. The following two lines contain the differential resistance and capacitance that will be placed into the IBIS file using a series [Model]. The last line of the code above is the current source that is used to cancel the differential current in the SPICE buffer model in order to be able to generate the correct V-T tables for the common mode [Model]s for the IBIS file. If the series [Model] uses the [Series Current] keyword instead of [R Series], a piecewise linear (PWL) current source can be used in place of the resistor in the above circuit. In case the series [Model] uses the [Series MOSFET] keywords, we would technically need a 3-dimensional PWL source, which is usually not available in most SPICE simulators. The best way to achieve a cancellation of this type is to use a “dummy” IBIS model instead of the resistor in the above circuit. A series [Model] would be used in this case; this series [Model] would be identical to that used in the final differential buffer model, but with reversed polarity to achieve the cancellation.

4.6.5 Additional Notes on Differential Data Extraction

The technique described in the previous sections provide a general methodology for extracting I-V and switching data for differential buffers, regardless whether they fall into the full, half-, or pseudo-differential category. In fact, the model maker does not even have to know what kind of differential buffer he or she is working with; the buffer can be treated as a black box for the purposes of this process, without concern for the design details.

Note that the series [Model] may not always need to be present in the final IBIS model. In general, a series [Model] will not be needed if there is no internal differential current flowing between the two signal terminals of

the buffer. How can we tell how much internal differential current flows between the two signal terminals of other differential buffers types without looking inside the design? How do we know whether the fully or half-differential buffer requires the series [Model]? On the other hand, how can we tell whether there is an on-die termination resistor (or equivalent) between the two signal terminals? One may think that these questions can only be answered with a detailed knowledge of the circuit schematics. What if the SPICE model is encrypted, or for some reason we can only treat it as a black box?

Fortunately, the answer to these questions can be found easily by going through the normal process of generating a set of I-V surfaces as described in the previous sections. After the differential I-V surface has been extracted, we just need to find the magnitude of the largest current on it. If the current is in the low μA , or nA range, we can conclude that the internal differential current is negligible, and we can safely omit the series [Model] from the final IBIS model. To put this into perspective, a 1 μA differential current with a 1 V differential voltage corresponds to a 1 M Ω differential impedance, which will most likely not affect the waveforms in a noticeable way in a 50 Ω transmission line environment.

In addition, a recent study revealed that many true or half-differential buffers have practically no internal differential current flow between the signal terminals unless there is a deliberate termination device designed into the buffer between those terminals. This explains why the traditional IBIS modeling approach using only two single-ended [Model]s as a differential pair was sufficient for most purposes. The study is available at:

<http://www.eda.org/pub/ibis/summits/feb04a/muranyi1.pdf>

A word of caution: the technique described above works well for differential buffers built with field effect (FET) output transistors, but may not provide accurate results when the output stage is made out of bipolar transistors. This can be explained with the stronger relationship that exists between the two output transistors' biasing through their pre-driver circuit.

4.7 C_comp and Differential Buffer Capacitance (C_diff)

The IBIS C_comp subparameter of a normal single-ended [Model] represents the capacitance that is found between the I/O pad and the supply rails of the buffer. For differential buffers it may also be necessary to describe the differential capacitance found between the non-inverting and inverting I/O pads. The IBIS specification does not have a dedicated parameter for this purpose, but one can use the [Series Pin Mapping] keyword with a [Model] that contains a [C Series] keyword to implement this differential capacitance. In the remaining part of this discussion, this differential capacitance will be referred to as C_diff.

As discussed earlier, C_comp for single-ended buffers can be obtained in a variety of ways, including through an AC or frequency-domain voltage sweep. The same technique can also be applied to differential buffers. However, for differential buffers we will need to connect an additional DC voltage source to the second terminal of the buffer. The voltage of this DC source should be the same as the DC offset of the AC source that is connected to the first output.

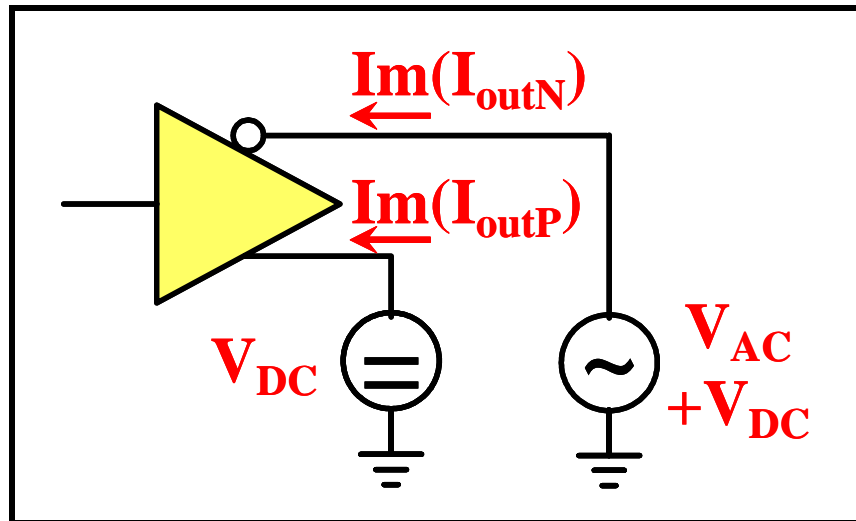

Figure 4.19 – Fixture for Extraction of Differential Buffer C_comp

The DC source will have an AC current reading only if there is a reactive path between the two output pads. Therefore, we can use the AC current reading obtained from the DC source to calculate C_diff directly, as shown in the following equation.

$$C_{diff} = -\text{Im}(I_{DC}) / (2 * \pi * f * V_{AC})$$

where $\text{Im}(I_{DC})$ is the imaginary part of the current measured through the DC voltage source, f is the frequency of the AC source, and V_{AC} is the amplitude of the AC source.

Please note that the current reading of the AC source will not only include the effects of the differential capacitance (C_{diff}), but also the effects of the common mode capacitance (C_{comp}) found between the output pad and the power supply rails. Therefore, to obtain C_{comp} alone, one must use the difference between $\text{Im}(I_{AC})$ and $\text{Im}(I_{DC})$ from the simulation results generated with the circuit shown above.

$$C_{comp} = -(\text{Im}(I_{AC}) - \text{Im}(I_{DC})) / (2 * \pi * f * V_{AC}), \text{ or}$$

$$C_{comp} = (\text{Im}(I_{DC}) - \text{Im}(I_{AC})) / (2 * \pi * f * V_{AC})$$

Please note that due to symmetry, this setup will yield the same results in most cases, regardless of the I/O pad to which the AC and DC sources are connected. However, if the buffer is not symmetric internally, the C_{comp} value may not be the same for both outputs. In such cases, the above measurement must be repeated with the two voltage sources reversed. The following figure shows a surface plot for C_{diff} as a function of voltage and frequency for a differential buffer.

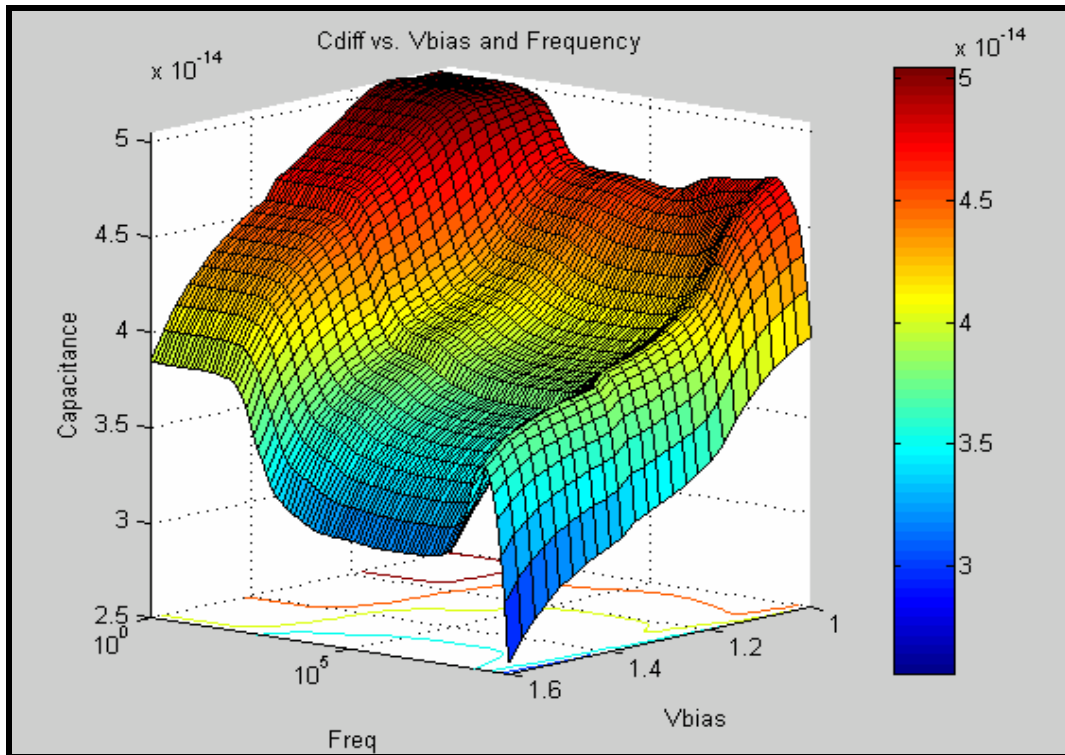

Figure 4.20 – Surface Plot of Differential Capacitance versus Frequency and DC Bias Voltage

Since the IBIS specification does not provide mechanisms to describe the buffer capacitance with such multidimensional data, we need to find a way to reduce the vast amount of information generated with the techniques described above. The easiest way to do this is to read the highest and lowest values from the surface plot and put them into the max., and min. places of C_comp or [C Series]. For the typical value, one can simply calculate the average of the maximum and minimum values. To find more meaningful values for these capacitances, one may apply a window to the surface plot using the frequency and voltage range in which the buffer is designed to operate before reading the maximum and minimum capacitance values from the surface.

5.0 Putting the Data into an IBIS File

By this point, a model maker should have a set of data showing the behavior of the buffer under a variety of environment and design conditions. The data set will include buffer strength (I-V tables) and, where appropriate, transient data (ramps or V-T tables) under several conditions. In addition, die capacitance information per corner should be available. All this data must now be reformatted into an IBIS model.

The basic objective of any attempt to convert such data to the IBIS format is to properly express the buffer's behavior in a way "understandable" to IBIS-compatible tools. This involves several aspects:

- basic syntax: representing the data under the proper IBIS keywords
- data checking: making sure the data is not self-contradictory
- data limiting: fitting the data within the IBIS size constraints
- redundancy prevention: ensuring that design aspects are not improperly "double-counted" under separate IBIS keywords

The following sections detail the specifics behind these steps.

The remainder of the document describes a bi-directional buffer – one capable of both driving a signal into a load and receiving a signal from an outside world. However, many other buffer types exist; where appropriate, the differences in treatment needed for these other types will be described.

The authors assume that the user either possesses a tool to convert data to IBIS format or is trying to perform this task manually. Several software tools exist to ease IBIS data conversions. These include S2IBIS3, a free SPICE-based conversion tool available through the IBIS Open Forum website (see *Resources* below).

5.1 Basic Syntax: Keywords and Their Definitions

An IBIS file consists of three parts, with an optional "external" package description. The three parts are:

1. general information about the file itself and the component being modeled
2. the component's name, pin-out and pin-to-buffer mapping
3. behavioral descriptions of each unique buffer design in that component

Note that an IBIS file can contain a description of more than one component (i.e., parts 2 and 3 above can be repeated several times within one IBIS text file). For more information, refer to the description of the [Component] keyword in the specification.

5.1.1 IBIS File Header Information

The first section of an IBIS file contains basic information about the file itself and the data in it. This section includes the following keywords:

Keyword	Required?	Description
[IBIS Ver]	Yes	What version of IBIS this file uses.
[Comment char]	No	Change the comment character. Defaults to the pipe () character
[File Name]	Yes	Name of this file. Remember that all file names must be lower case. The file name extension for an IBIS file is .ibs
[File Rev]	Yes	The revision level of this file. The specification contains guidelines for assigning revision levels.
[Date]	No	Date this file was created
[Source]	No	The source of the data in this file. Is it from a data book? Simulation data? Measurement?
[Notes]	No	Component or file specific notes. Please see the discussion below.
[Disclaimer]	No	May be legally required
[Copyright]	No	The file's copyright notice

Table 5.1 – IBIS File Header Keywords

The use of these keywords is self-explanatory. Note that while the [Date], [Source], etc. keywords are not required, their use is strongly recommended. The [Notes] keyword is especially valuable, in that the model creator can include in the IBIS file such information as:

- Specific model and simulator use information. For example, if the file is marked as IBIS version 2.1 the [Notes] keyword may specify what specific version 2.1 features a simulator must support. Specific model use requirements or caveats may also be described here.
- Information on SSO conditions. Under what switching conditions (i.e., how many SSOs) were the minimum, typical and maximum corners derived? Was the buffer's Tco taken under the same conditions (it should have been)?
- Additional package modeling information may be included
- The model's validation level may also be described

5.1.2 Component and Pin Information

This section of an IBIS file is where the “data book” information regarding the component's pinout, pin to buffer mapping, and the package and pin electrical parameters are placed.

Keyword	Required?	Description
[Component]	Yes	The name of the component being modeled. Standard practice has been to use the industry standard part designation. Note that IBIS files may contain multiple [Component] descriptions.
[Manufacturer]	Yes	The name of the component manufacturer
[Package]	Yes	This keyword contains the range (minimum, typical and maximum values) over which the packages' lead resistance, inductance and capacitance vary (the R_pkg, L_pkg and C_pkg parameters).
[Pin]	Yes	This keyword is where the pin to buffer mapping information is put. In addition, the model creator can use this keyword to list the R, L and C data for each individual pin (R_pin, L_pin and C_pin parameters).
[Package Model]	No	If the component model includes an external package model (or uses the [Define Package Model] keyword within the IBIS file itself) this keyword indicates the name of that package model.
[Pin Mapping]	No	This keyword is used if the model creator wishes to include information on buffer power and ground connections. This information may be used for simulations involving multiple outputs switching. Please see <i>Advanced Keywords and Constructs</i> for instructions on using this keyword.
[Diff Pin]	No	This keyword is used to associate buffers that should be driven in a complementary fashion as a differential pair. Please see section <i>Advanced Keywords and Constructs</i> for instructions on using this keyword.

Table 5.2 – IBIS Component and Pin Information

Note that for some components the required keywords [Component], [Manufacturer], [Package] and [Pin] are all that are needed to build the model. The [Pin] keyword is where the pins of the component are defined, and each of the buffer models created are mapped to specific pins. As described in the specification, there must be a buffer model (as called out by the [Model] keyword) for each pin that is not a power, ground or no-connect.

R_pkg, L_pkg and C_pkg are the overall (min and max) values of the package's resistance, inductance and capacitance. The *numerically largest* values of R, L and C are listed as the “max” values, while the *numerically smallest* values of R, L and C are listed as the “min” values.

A subtlety of the IBIS specification for version 4.0 and previous versions is that buffers are instantiated through the [Pin] keyword. In other words, a one-to-one correspondence is assumed between component pins and buffers, though no explicit die pads are named. Package models are assumed to connect these two points. While convenient, this assumption effectively prohibits package definitions involving a single pin and multiple die pads, or a single die pad and multiple pins, under IBIS versions below 4.1.

5.1.3 The [Model] Keyword

The [Model] keyword starts the description of the data for a particular buffer. While a buffer model can appear quite complex, most buffers can be described using just a few of the parameters and keywords.

5.1.3.1 Parameter Section

A model description starts with the user specifying a few basic parameters. These parameters tell the simulator what type of buffer the model represents, and include some “data book” characteristics of the buffer that enable simulators to do automatic error checking.

[Model] Parameter	Required	Description
Model_type	Yes	Defines the type of buffer (input, output, I/O, etc.)
Polarity	No	The polarity of the signals driven by this buffer (high true or low true).
Enable	No	The polarity of this buffer’s output enable signal (if applicable)
Vinl, Vinh	No	The buffer’s input logic thresholds
C_comp	Yes	Buffer input or output capacitance. Note the discussion on “min” and “max” values of C_comp included in the text below. C_comp_pullup, C_comp_pulldown, C_comp_power_clamp, C_comp_gnd_clamp are optional.
Vmeas, Cref, Rref, Vref	No	Provides the simulator with this buffer’s Tco measurement conditions

Table 5.3 – IBIS [Model] Subparameters

The IBIS specification gives an extensive list of possible buffer types. Peruse this list carefully to choose your buffer type. Note that if an input or I/O buffer type is chosen the user must specify the Vinl and Vinh parameters or verify that the IBIS defaults are correct. The Vinl and Vinh parameters are included so that simulators can flag signal integrity violations and perform timing calculations. In addition, though not required, all output or I/O type buffer models should include the Vmeas, Cref, Rref and Vref parameters. Including these parameters allows a simulator to perform board level timing calculations.

Note that when constructing the IBIS file the *numerically largest* value of C_comp is listed as the “max” value while the *numerically smallest* value of C_comp is listed as the “min” value. C_comp min and max values do not necessarily correlate with the min and max conditions under which the I-V and switching data was gathered. The actual association of C_comp corner values with simulation corners is performed at the tool level.

5.1.3.2 Temperature and Voltage Keywords

Once the basic buffer type and data book parameters have been specified the temperature and voltage ranges over which the buffer operates is given by the following keywords.

Keyword	Required?	Description
[Temperature Range]	No	The temperature range over which the min, typ and max I-V and switching data has been gathered. If not specified then 0, 50 and 100 degrees C is assumed.
[Voltage Range]	Yes	The range over which Vcc is varied to obtain the min, typ and max pullup and power clamp data.
[Pullup Reference] [Pulldown Reference] [POWER Clamp Reference] [GND Clamp Reference]	No	Allows the user to specify alternate references (i.e., voltage rails) for any of the four I-V tables.

Table 5.4 – IBIS [Model] Temperature and Voltage Keywords

The [Temperature Range] keyword follows an ordering rule different from the C_comp subparameter. Note that the minimum and maximum temperature values listed in an IBIS file correspond to the conditions under which the minimum and maximum I-V and switching data was taken. For example, if the minimum (weakest drive, slowest edge) data was taken at 85 degrees C, and the maximum data were taken at 0 degrees C, then “85” would be entered in the minimum column and 0 would be entered into the maximum column. Note that these conditions may be different for different technologies; for example, weak or slow CMOS buffer behavior may be found at high temperatures while weak or slow BJT buffer behaviors are more likely found at low temperatures.

The [Voltage Range] keyword specifies the range over which the buffer’s supply is varied to obtain the min, typ and max conditions. In addition, this keyword supplies the default voltage reference value for the pullup and power clamp I-V tables. Normally, the [Voltage Range] keyword is all that is required. However, if a buffer uses multiple power supply rails the alternate keywords are used. Very specifically, if the model creator gathers pullup or power clamp I-V data using a voltage reference other than that called out by the [Voltage Range] keyword, then the [Pullup Reference] or [POWER Clamp Reference] keywords are used.

The following simple diagram represents the concept behind almost any single-ended IBIS model, regardless of its design complexity.

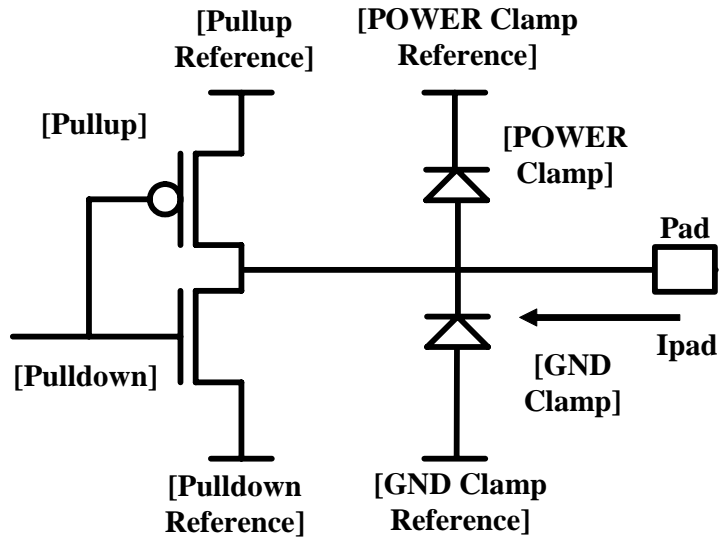

Figure 5.1 – Conceptual Diagram of Model Keyword Structure

The [Pullup] and [Pulldown] keywords include information on the driver’s strength when it drives high or low, respectively. [POWER Clamp] and [GND Clamp] include information on the clamping behaviors of buffers when receiving or in a high-impedance state. While many buffers are much more complex than this diagram indicates, the DC characteristics of the buffer can be expressed using these keywords.

The diagram below portrays more detail of the actual connections and electrical relationships between a CMOS buffer and the IBIS [Model] I-V keywords.

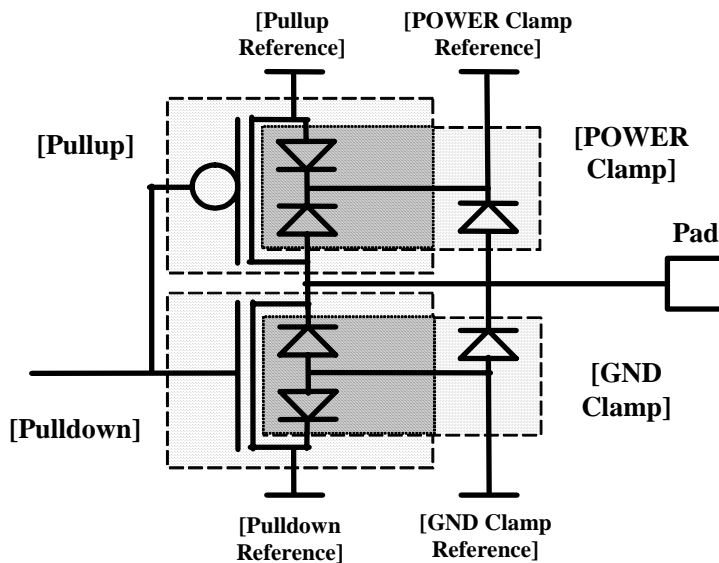

Figure 5.2 – Model Keyword Structure with Added Diode Detail

The drawing illustrates that the bulk or substrate connections of the driving transistors would be connected to the [GND Clamp Reference] in the case of the [Pulldown] or the [POWER Clamp Reference] in the case of the [Pullup]. The transistors’ parasitic diodes will appear in the extracted [POWER Clamp] and [GND Clamp] tables, in addition to any discrete diode structures connected to the buffer pad.

A summary of the I-V keywords is shown below.

Keyword	Required?	Description
[Pulldown]	No	Data representing the output I-V behavior of a buffer in the logic low state. This keyword is not used for input or open-source buffers. Depending on Model_type, the data may or may not include clamping effects. The data for this keyword is assumed ground-relative or relative to [Pulldown Reference], if present.
[Pullup]	No	Data representing the output I-V behavior of a buffer in the logic high state. This keyword is not used for input buffers or open-sink buffers. Depending on Model_type, the data may or may not include clamping effects. The data for this keyword is assumed Vcc-relative or relative to [Pullup Reference], if present.
[GND Clamp]	No	I-V table when the input or output of a buffer is in a high-impedance state. The voltage sweep is assumed ground-relative or relative to [GND Clamp Reference], if present.
[POWER Clamp]	No	I-V table when the input or output of a buffer is in a high-impedance state. The voltage sweep is assumed Vcc-relative or relative to [POWER Clamp Reference], if present.

Table 5.5 – [Model] I-V Table Keywords

Buffers may be modeled using different combinations of I-V keyword tables depending on their Model_type. Input buffers include only the [GND Clamp] and/or [POWER Clamp] keywords, which are used to describe the diode clamping behavior of the buffer. Output-only buffers usually contain only [Pullup] and [Pulldown] tables, as their clamping behaviors cannot be isolated from their low or high output states. I/O buffers may drive or receive signals, and so all four I-V keywords are usually present for these types. 3-state buffers, though incapable of receiving signals, can drive or be placed in a high-impedance state where only clamping behaviors are evident. As a result, 3-state buffers also usually contain all four I-V keywords (as I/O and 3-state buffers have identical structures from an IBIS perspective, all recommendations below relating to I/O buffers should be assumed to apply to 3-state buffers as well). Other buffer types, such as I/O_open_source, Open_drain and the like, contain combinations of the four I-V keywords appropriate to their driving and receiving capabilities.

Note that the [Pullup] table for a buffer of Model_type Output and [Pullup] data for a buffer of similar design of Model_type I/O will not be identical, if the Output buffer does not contain [GND Clamp] or [POWER Clamp] tables. Output buffers, if no explicit clamp tables are present, have their clamp behaviors included in their [Pullup] and [Pulldown] tables. I/O buffers should include clamp behaviors only in the clamp tables and their [Pullup] and [Pulldown] I-V tables should have had their clamping effects subtracted out to avoid “double-counting” them. When simulation tools use I/O buffer data, they will add the clamp and [Pullup] data together when the buffer drives a high output, and sum the clamps and [Pulldown] data for low driven output. When the buffer receives, the simulation tool will make use only of the clamp tables.

5.1.3.3 I-V Keyword Table Referencing

The I-V data present in the [Pullup], [POWER Clamp], [Pulldown] and [GND Clamp] keyword tables does not use the same reference supply voltages in all cases. If only the [Voltage Range] keyword is used in the relevant model, the [Pullup] and [POWER Clamp] table voltages are assumed to be with respect to the [Voltage Range] values and the [Pulldown] and [GND Clamp] table voltages are assumed to be with respect to 0 V or ground. An overlay of all three corners of a [POWER Clamp] for a buffer with no leakage and internal terminations, if plotted relative to the supply voltage, would show all three curves passing through the graph origin.

If additional supply keywords – [Pullup Reference], [Pulldown Reference], [POWER Clamp Reference] and [GND Clamp Reference] – are used, [Model] I-V table voltages are shown with respect to their associated reference voltages. For instance, if [POWER Clamp Reference] and [POWER Clamp] are present in a particular [Model], the [POWER Clamp] I-V table voltages are assumed shown with respect to the [POWER Clamp Reference] voltage values (i.e., the origin of a graph of the table data would be equal to the reference voltage).

IBIS [Model] I-V table voltage points may be calculated using the formula:

$$V_{\text{table}} = V_{\text{reference}} - V_{\text{output}}$$

This equation assumes that $V_{\text{reference}}$ and V_{output} are ground-relative. For example, imagine a standard 5 V buffer is analyzed using a voltage supply connected to ground. For purposes of generating a [POWER Clamp] table, data is needed from V_{cc} to $2*V_{\text{cc}}$ with respect to ground; here, from +5 V to +10 V. This data would be listed in the [POWER Clamp] table relative to 5 V, spanning a table voltage range from -5 V to 0 V.

5.1.3.4 Ground Clamp

I-V data for the ground-connected diode clamping effects is entered in the [GND Clamp] keyword table. For I/O buffers this is the ground-relative data gathered while the buffer was in a non-driving or high impedance state. According to the IBIS specification, the data in table must cover a minimum range of $-V_{\text{cc}}$ to V_{cc} , measured relative to ground or, if the keyword is present, the [GND Clamp Reference] keyword value for that corner.

The raw I-V table for a buffer in a receiving or high impedance state will show both ground and power clamping effects. These effects must be separated in the [GND Clamp] and [POWER Clamp] tables to ensure that, when the table data is summed again by the simulation tool, no effects are double counted. For the [GND Clamp] table, the raw ground clamp data from lab or simulation extraction should be “cut” at V_{cc} and the data above V_{cc} discarded. The table should then be extrapolated to $2*V_{\text{cc}}$ for the final I-V table. If power clamp data is properly processed, as will be shown below, this extrapolation will help ensure good simulator behavior when the clamp data is summed.

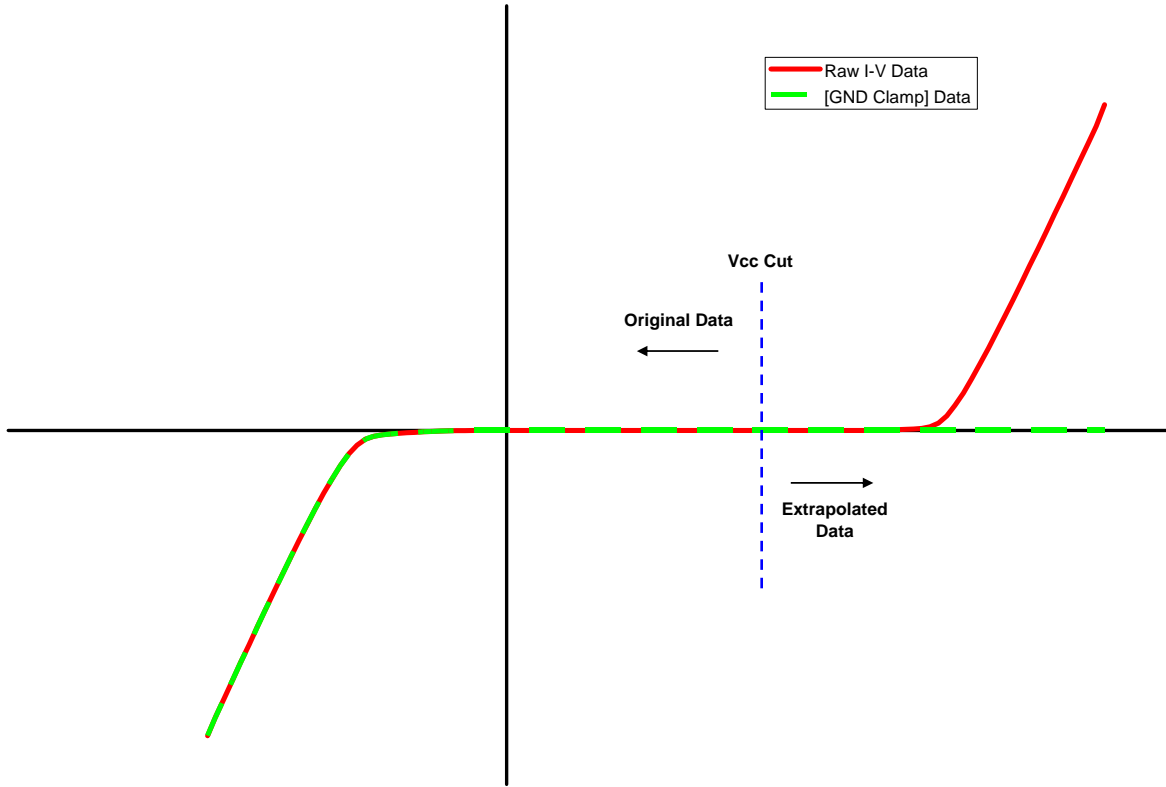

Figure 5.3 – Raw I-V and Extrapolated Final [GND Clamp] Data Graphs

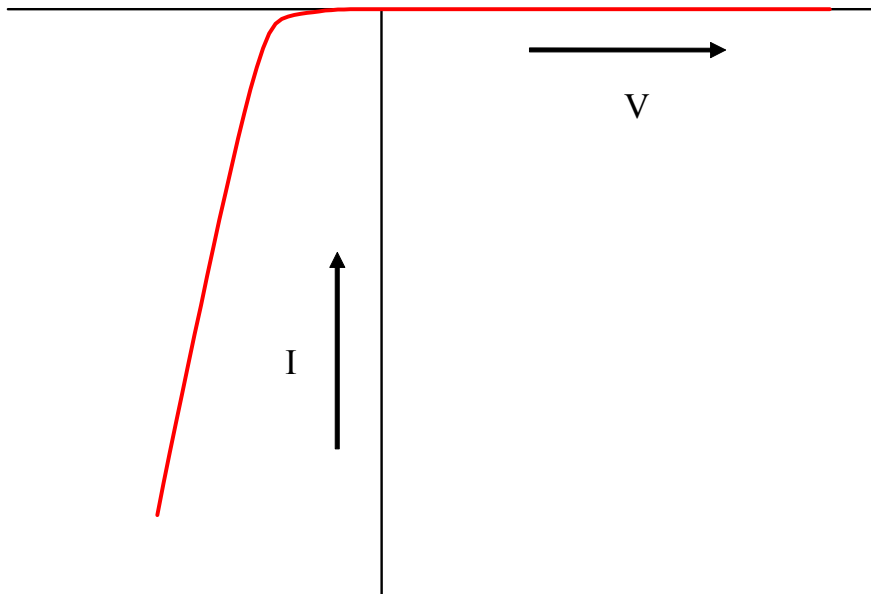

Figure 5.4 – Graph of [GND Clamp] I-V Table Data

5.1.3.5 Power Clamp

The power clamp I-V data is entered into the [POWER Clamp] keyword table.

As noted above for the [GND Clamp], the [POWER Clamp] data must cover, at a minimum, the range of V_{cc} to $2 \cdot V_{cc}$ (ground-relative). This must be presented in the final table as V_{cc} -relative, from $-V_{cc}$ to 0 V. Once the raw high impedance I-V table, generated as described in *Extracting the Data – Single-ended Buffers*, is made V_{cc} -relative, it should be “cut” at 0 V and the data above 0 V discarded. Again, as with the [GND Clamp], the final table should be extrapolated from 0 V to $2 \cdot V_{cc}$, V_{cc} -relative, to ensure optimal behavior when the data are summed by the simulation tool.

The relationship of the raw high impedance I-V tables to the final table data is shown graphically below. Be aware that the I-V response may be different if the sweeps are performed in different directions (i.e., from low voltage to high voltage and from high voltage to low voltage).

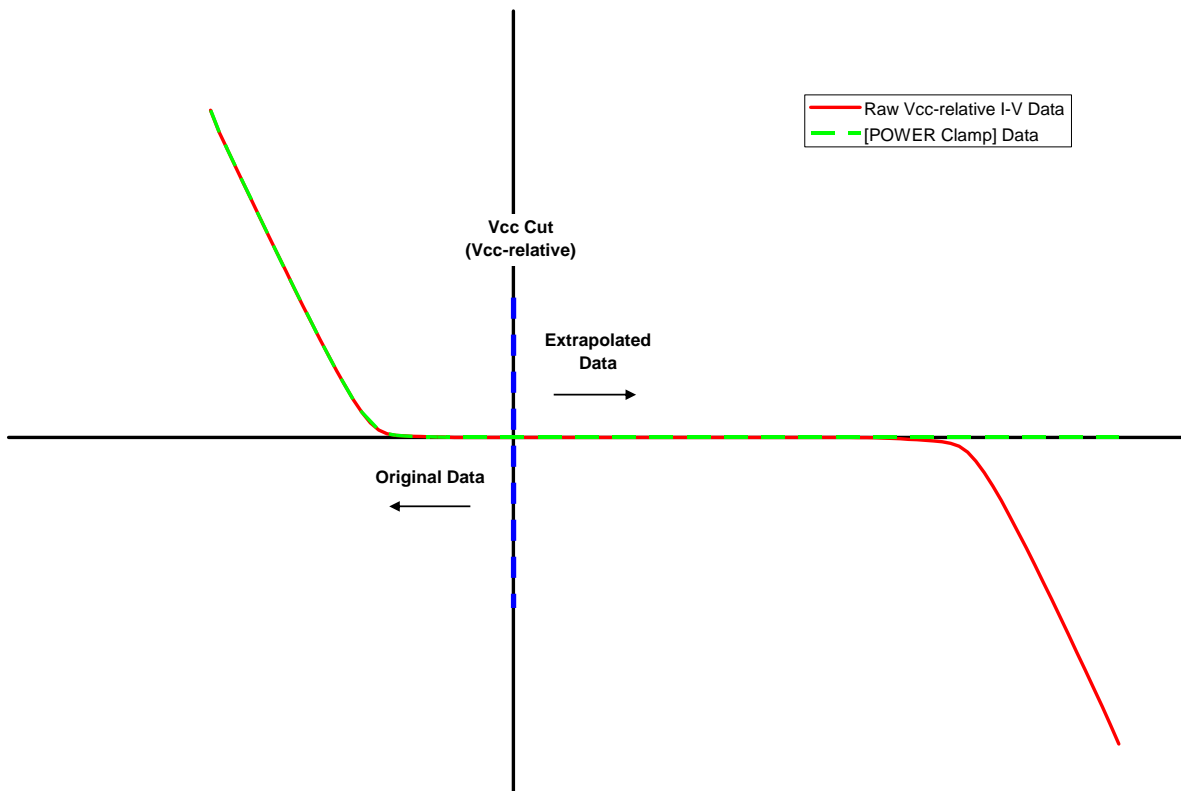

Figure 5.5 – Raw I-V and Extrapolated Final [POWER Clamp] Data Graphs

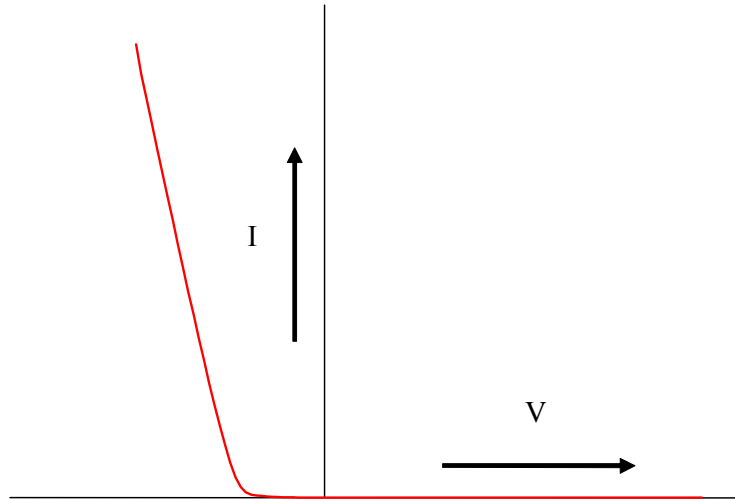

Figure 5.6 – Graph of [POWER Clamp] I-V Table Data after Clamp Subtraction

5.1.3.6 Pulldown

The [Pulldown] table contains the I-V data gathered while the output or I/O buffer was in the logic low state. To satisfy the minimum requirements of the IBIS specification, [Pulldown] keyword data must cover the range of $-V_{cc}$ to $2 \cdot V_{cc}$. If the buffer is of Model_type I/O then first subtract the ground clamp and power clamp currents from the pulldown current and enter the result into the [Pulldown] table (note that the same referencing for the ground and power clamp data should be observed before subtraction).

As an example, a 2.0 V buffer will have a pulldown I-V response that resembles Figure 5.7. Below zero volts the buffer's current may start to increase (become more negative), but then head back towards zero. When tools perform simulations with the buffer in its active state, a simulator sums the ground clamp I-V table with the pulldown I-V table to arrive back at the original pulldown I-V table.

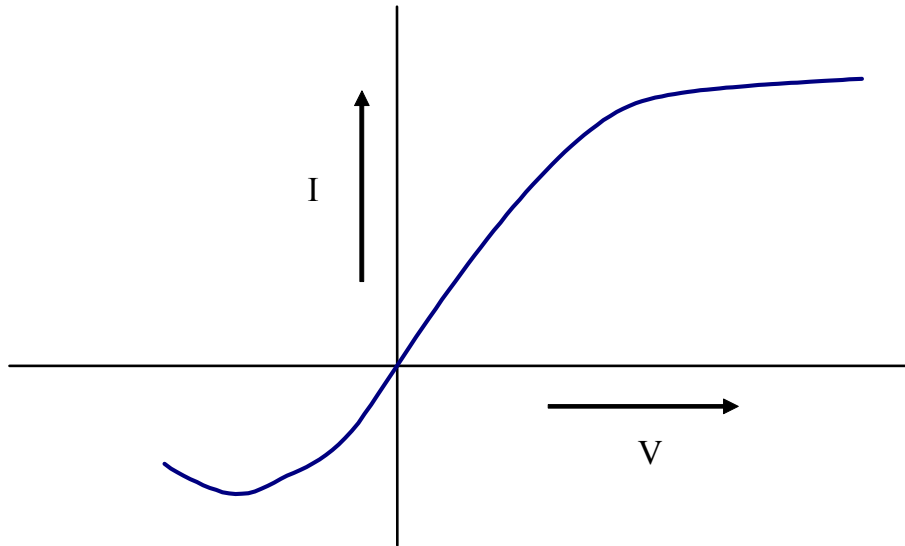

Figure 5.7 – Graph of [Pulldown] I-V Table Data, after Clamp Subtraction

5.1.3.7 Pullup

The [Pullup] table contains the I-V data gathered while the output or I/O buffer is in the high logic state. Again, if the buffer is of Model_type I/O, then first subtract the power clamp and ground clamp currents from the pullup current then enter the result into the [Pullup] table (note that the same referencing for the ground and power clamp data should be observed before subtraction). Pullup data must cover the range $-V_{cc}$ to $2*V_{cc}$ in the final table.

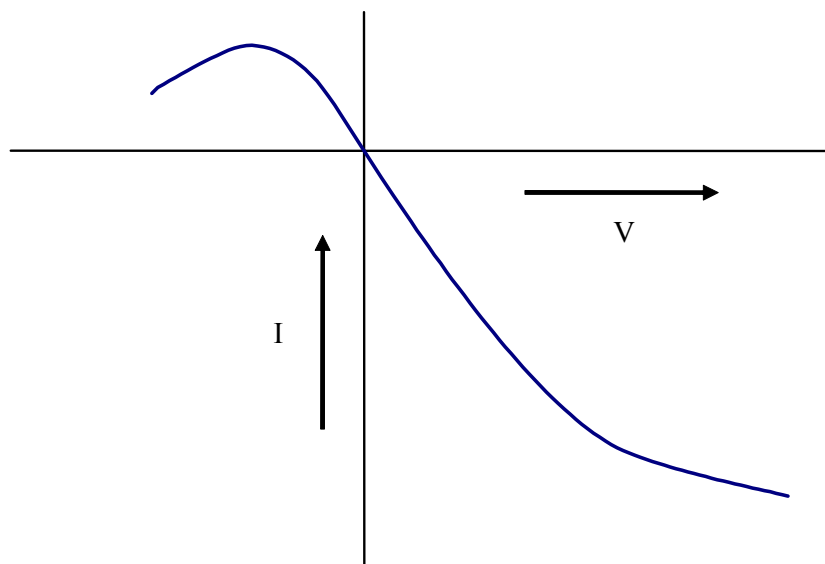

Figure 5.8 – Graph of [Pullup] I-V Table Data after Clamp Subtraction

5.1.3.8 Summary of Extraction Ranges

Table 5.6 below summarizes the ranges over which to present I-V table data in the final IBIS model. Note that the referencing will change from ground and Vcc in the table if [POWER Clamp Reference], [GND Clamp Reference], etc. are used.

I-V Keyword Table	Specification Minimum Range	Recommended Range
[GND Clamp]	-Vcc to Vcc (ground-referenced)	-Vcc to 2*Vcc (ground-referenced)
[POWER Clamp]	0 to -Vcc, Vcc-referenced in model (+Vcc to 2*Vcc, ground-referenced)	-Vcc to 2*Vcc (Vcc-referenced)
[Pulldown]	-Vcc to 2*Vcc (ground-referenced)	-Vcc to 2*Vcc (ground-referenced)
[Pullup]	-Vcc to 2*Vcc, Vcc-referenced (-Vcc to 2*Vcc, ground-referenced)	-Vcc to 2*Vcc (Vcc-referenced)

Table 5.6 – Summary of Recommended I-V Table Sweep Ranges

5.1.3.9 Extrapolation Errors

One common error when building clamp tables involves extrapolation. Most simulators extrapolate the data points in a table to calculate values beyond the table's range. For example, examine the [GND Clamp] in Table 5.7 below (typical corner only shown):

Voltage	Current
-1.5 V	-120 mA
-1.0 V	-60 mA
0.0 V	0 mA

Table 5.7 – Poorly Extrapolated [GND Clamp] Table, Typical Corner

If a simulation tool needs to calculate the circuit response for -2.0 V, it may extrapolate the first two rows in the table to obtain -180 mA at that voltage level. Similarly, if a simulation tool needs the response at 1.0 V based only on this table's information, it may extrapolate the last two rows in the table to obtain 60 mA at that voltage level.

For most buffers with [GND Clamp] tables where power clamping diodes are described under [POWER Clamp] tables the currents above 0 V are likely to be effectively zero if no on-die termination or leakage is present. Therefore, while the extrapolation below -1.5 V may be appropriate, the extrapolation above 0.0 V as described above is likely not. To ensure correct extrapolation, additional points should be added to the table. In this case, an additional 0 mA point above 0.0 V is necessary, as shown in Table 5.8 below:

Voltage	Current
-1.5 V	-120 mA
-1.0 V	-60 mA
0.0 V	0 mA
0.5 V	0 mA

Table 5.8 – [GND Clamp] Table, Typical Corner, with Improved Extrapolation

A similar approach applies to [GND Clamp] or [POWER Clamp] data tables in which on-die termination effects are included (see below). The slope of the curve in the region where diodes are not conducting will be determined by the termination and any extrapolation should be appropriate to the behavior of the termination and the diodes in that region.

Extrapolation can also help to eliminate noise in I-V table data due to subtraction or other computation issues. Small variations in I-V data extracted during different sweeps, for example, may result in large changes in [POWER Clamp] or [GND Clamp] data for the non-clamping regions. If the I-V data cannot otherwise be filtered before inclusion in the IBIS file, extrapolation will prevent distortion in the summed I-V curves used by the simulation tool. Not all tools are guaranteed to use IBIS I-V data in the same way.

In general, all I-V tables should be generated ensuring that any extrapolation by simulation tools will result in a correct representation of the buffer's behavior in the extrapolated region.

5.1.3.10 [Ramp] and Waveform Tables

The last piece of information about an output or I/O buffer is the switching information. This information is contained in the following keywords:

Keyword	Required?	Description
[Ramp]	Yes	Basic ramp rate information, given as a dV/dt_r for rising edges and dV/dt_f for falling edges.
[Rising Waveform]	No	The actual rising (low to high transition) waveform, given as a V-T table.
[Falling Waveform]	No	The actual falling (high to low transition) waveform, given as a V-T table.

Table 5.9 – [Ramp] and Waveform Table Keywords

The [Ramp] keyword is always required, even if the [Rising Waveform] and [Falling Waveform] keywords are used. It is important to note that the ramp rate is **not** the instantaneous slew rate of the output. Instead, it is a number that indicates how long it takes the output transistor structures to switch from one state to another. Specifically, the “ramp rate” as posted in an IBIS file is defined as:

$$\frac{dV}{dt} = \frac{\text{20\% to 80\% voltage swing}}{\text{Time taken to swing above voltage}}$$

The dV portion of [Ramp] is **not** equivalent to the unloaded full swing of the buffer output. Rather, the dV value is the 20% to 80% swing of the buffer when driving into the specified load, R_load (for [Ramp], this load defaults to 50 Ω). For CMOS drivers or I/O buffers, this load is assumed to be connected to the voltages defined by the [Voltage Range] keyword for falling edges and to ground for rising edges.

For example, if a buffer's typical falling edge output swings from 3.3 V to 0.8 V for a resistive load of 60 Ω connected to 3.3 V, the dV part of the typical dV/dt_f column of [Ramp] would be 0.6 * (3.3 – 0.8) or 1.5. R_load would be set to 60.

While not checked by IBISCHK4, the dV portion of [Ramp] should also match the I-V table intercept voltages for the given load. For the example above, where R_load is 60 Ω, the pulldown I-V table should intercept a 60 Ω load line at 0.8 V. For this reason, do not reduce the dV/dt data under [Ramp] to a single slew rate number.

In general, V-T tables under [Rising Waveform] and [Falling Waveform] are preferred to [Ramp] for several reasons. Primarily, V-T data may be provided under a variety of loads and termination voltages, while only one set of [Ramp] data, for only a single resistive load and set of termination voltages, may be provided for any [Model]. Additionally, [Ramp] only provides transition data for devices as they turn on, not as they turn off; V-T tables may be used to describe both types of state changes. Finally, [Ramp] effectively averages the transitions of the device, without providing any details on the shapes of the transitions themselves. For example, a transition that is ideally linear and another transition that features ledges or “stair-steps” would be described using the same [Ramp] data if the overall time taken by both transitions is the same. All detail of the transition ledges would be lost in the [Ramp] representation. For these reasons, [Rising Waveform] and [Falling Waveform] data should be supplied whenever possible.

5.1.3.11 Keywords and Specific Buffer Types

The IBIS standard allows a variety of buffer types to be described with I-V and V-T tables. Table 5.10 and Table 5.11 below show the minimum recommended data for any buffer type.

Model_Type	[Pullup]	[Pulldown]	[POWER Clamp]	[GND Clamp]	Notes
Input	n/a	n/a	Recommended	Recommended	
I/O	Required	Required	Recommended	Recommended	
I/O_open_sink I/O_open_drain	n/a	Required	Recommended	Recommended	1
I/O_open_source	Required	n/a	Recommended	Recommended	1
Open_sink Open_drain	n/a	Required	Recommended	Recommended	4
Open_source	Required	n/a	Recommended	Recommended	4
Output	Required	Required	Recommended	Recommended	4
3-state	Required	Required	Recommended	Recommended	2
Series_switch	n/a	n/a	n/a	n/a	3
Series	n/a	n/a	n/a	n/a	3
Terminator	n/a	n/a	Recommended	Recommended	3
Input_ECL	n/a	n/a	Recommended	Recommended	
I/O_ECL	Required	Required	Recommended	Recommended	2
Output_ECL	Required	Required	Recommended	Recommended	4
3-state_ECL	Required	Required	Recommended	Recommended	2

1. Keywords listing “n/a” may be included if the currents are set to 0 for all voltage points
2. Functionally similar to I/O, but without input threshold information (Vinh, Vinl, etc.)
3. Special syntax required; use of clamp data on pins which also feature buffers using these Model_types is allowed
4. Clamp data may technically be excluded; however, this data aids analysis of reflections arriving at the driving buffer

Table 5.10 – I-V Table Keywords and Buffer Types

Strictly speaking, V-T tables are not required under the IBIS specification. However, for more accurate modeling, certain combinations of V-T tables are recommended for IBIS version 2.1 and above. These are described in Table 5.11 below.

Model_type	[Rising Waveform]		[Falling Waveform]		Notes
	Load to Vcc	Load to GND	Load to Vcc	Load to GND	
Input	n/a	n/a	n/a	n/a	
I/O	Recommended	Recommended	Recommended	Recommended	
I/O open drain	Recommended	n/a	Recommended	n/a	1
I/O open_source	n/a	Recommended	n/a	Recommended	1
I/O open_sink I/O open_drain	Recommended	n/a	Recommended	n/a	1
Open_source	n/a	Recommended	n/a	Recommended	
Open_sink Open_drain	Recommended	n/a	Recommended	n/a	
3-state	Recommended	Recommended	Recommended	Recommended	
Series_switch	n/a	n/a	n/a	n/a	2
Series	n/a	n/a	n/a	n/a	2
Output	Recommended	Recommended	Recommended	Recommended	
Terminator	n/a	n/a	n/a	n/a	
Input ECL	n/a	n/a	n/a	n/a	
I/O ECL	Recommended (to Vcc - 2)		Recommended (to Vcc - 2)		3
Output ECL	Recommended (to Vcc - 2)		Recommended (to Vcc - 2)		3
3-state ECL	Recommended (to Vcc - 2)		Recommended (to Vcc - 2)		3

1. The presence of internal terminations may require adding waveforms in place of “n/a”
2. Special syntax required
3. For ECL, the fixture is Vcc-2; multiple waveforms to various voltage using the same load impedance may be useful in some contexts

Table 5.11 – V-T Fixtures and Buffer Types

For example, an IBIS buffer of Model_type “I/O” will generally contain four sets of I-V tables: [Pulldown], [Pullup], [GND Clamp] and [POWER Clamp]. In addition, such a buffer must contain, at minimum, a [Ramp] section with both rising and falling dV/dt values. Should V-T data be extracted for this buffer, the data should be included under two [Rising Waveform] and two [Falling Waveform] sections, each containing data tables for a Vcc-connected load and a ground-connected load, though other loading combinations are permitted. The recommended loading combinations for a simple CMOS buffer are shown in Table 5.12 below.

IBIS Keyword	Transition	Load
[Falling Waveform]	Pulldown turning on	Resistor to Vcc
[Rising Waveform]	Pulldown turning off	Resistor to Vcc
[Rising Waveform]	Pullup turning on	Resistor to GND
[Falling Waveform]	Pullup turning off	Resistor to GND

Table 5.12 – V-T Table Loading Recommendations

Note that while Vcc and ground are recommended as fixture voltages, additional waveforms with other load conditions may be used.

5.1.3.12 Differential Buffers

Note that the above tables do not include any mention of differential buffers. IBIS has no specific [Model] buffer type parameter to describe differential behavior. Instead, differential buffers are included in an IBIS file through a two-step process:

- add a [Diff Pin] section for differential inverting and non-inverting pins (see [Diff Pin] below)
- for symmetric designs, use the same single-ended model for both inverting and non-inverting pins

IBIS can be used to model and simulate differential behaviors through tying two single-ended buffers together and providing input stimuli of opposite polarities. For example, if a differential driver were to be created and one has single-ended buffer data for the model “TESTMODEL,” one would begin by creating two pins in the [Pin] list, each using the model “TESTMODEL.” The [Diff Pin] section of the IBIS file would show one of these pins as an inverting output and the other as the non-inverting output.

When a simulation is to be performed, so long as the two “TESTMODEL” buffers are provided with input signals which are opposite in polarity, the buffers will act in a differential fashion. Many simulation tools will ensure opposing polarities of input waveforms automatically if the [Diff Pin] keyword is present.

If the differential data collection procedures mentioned above were followed, a differential C_comp may be expressed using the [C Series] keyword described below.

5.2 Data Checking

Several data checks are critical to ensure final IBIS models that are useful in simulation:

- data completeness
- I-V and V-T matching

5.2.1 Data Completeness

Fundamentally, data completeness means having sufficient data to create a useful IBIS model. Users should ensure that their extracted information includes:

- I-V data covering the appropriate ranges for all corners
- I-V data covering sufficient data points to describe buffer behavior
- I-V data showing behavior for all appropriate input states (high, low, high-Z)
- V-T data covering sufficient data points to describe buffer behavior
- V-T data (where appropriate) showing complete transitions (settled low to settled high)
- V-T data (where appropriate) showing two to four or more transitions into a load

See *Extracting the Data* for more information on generating complete data.

5.2.2 I-V and V-T Matching

For a model of any buffer capable of driving a signal (this includes bi-directional buffers, output-only buffers and the like), one of the most critical concepts is I-V to V-T matching. In other words, the settled or DC behavior seen at the start and end of a transition from high-to-low or vice-versa must be consistent with the I-V table data for the buffer under the same environmental conditions and under the same load.

The diagram below shows a simple buffer driving a load, connected to ground. The buffer is stimulated to drive from a low output state to a high output state. The voltage-versus-time table for this loaded buffer's transition is shown in Table 5.13 below.

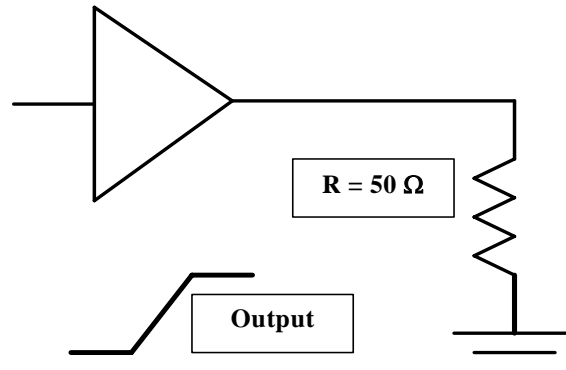

Figure 5.9 – Diagram of Resistive Load for Rising Waveform

Time	V(typ)
0.000E+00	0.00E+00
1.000E-11	2.30E-08
2.000E-11	4.39E-04
3.000E-11	2.02E-02
4.000E-11	3.52E-02
5.000E-11	6.49E-02
{...}	{...}
1.800E-10	2.17E+00
1.900E-10	2.18E+00
2.000E-10	2.19E+00

Table 5.13 - Example V-T Table Data for Rising Waveform

If we draw the buffer driver in its most simple form, its behavior can be represented as nothing more than a pullup transistor and a pulldown transistor with connected inputs and connected outputs – an inverter (a CMOS example is shown).

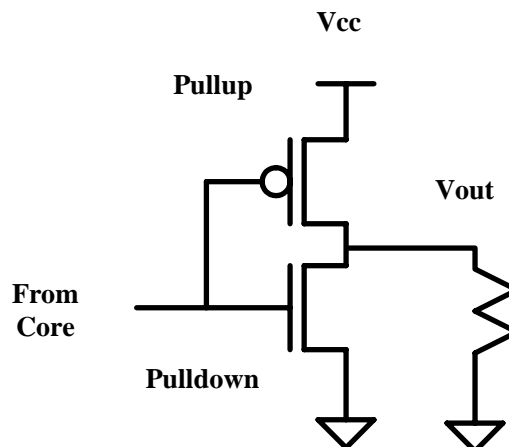

Figure 5.10 – V-T Table Loading Example

If the signal at the input (“From Core”) is transitioning from high to low, the output will transition from low to high. Under ideal conditions, no current will flow through the pulldown transistor and the core is driving low.

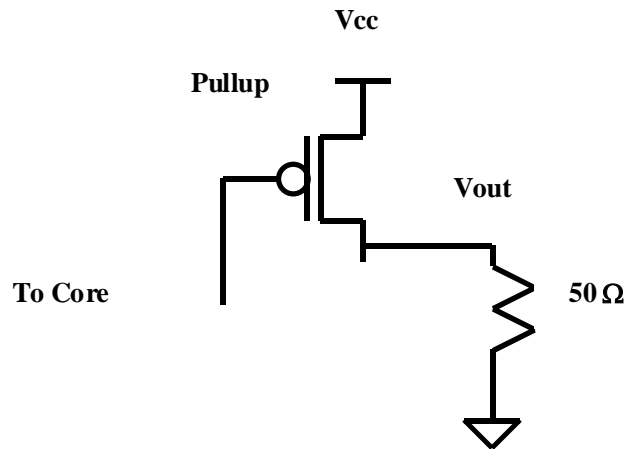

Figure 5.11 – V-T Table Loading Example, Simplified

The voltage of our transient waveform describes the voltage between the resistor and the transistor as the transistor turns on, starting with little to no current flow (off) to maximum current flow (on). When at the end of its low-to-high output transition – when fully on – the transistor is, in essence, a non-linear resistor, which will provide differing current flows dependent on gate voltage and source-to-drain voltage (this should sound familiar from basic electronics, when speaking of transistor curve-tracing or bias tables).

Since our gate, source and drain voltages are fixed by the design and the load, we end up with a single current through the transistor when it is fully on, at the end of our V-T table. ***This current should match the same current for a load line of 50 Ω drawn across the I-V curve of our transistor.*** As our I-V curve shows transistor strength and is a DC description of the transistor behavior, the end point of our V-T table – also a DC condition, as the transistor is fully on – should match the I-V for the same load.

Numerically, our example shows the buffer’s transient output to have fully settled at 2.1895 V into a 50 Ω load. This implies a fully-on transistor current of approximately 43 mA, by Ohm’s Law.

By drawing a load line of 50 Ω across the (Vcc-referenced) I-V curve for this buffer, we can see that the intercept point is indeed approximately 43 mA.

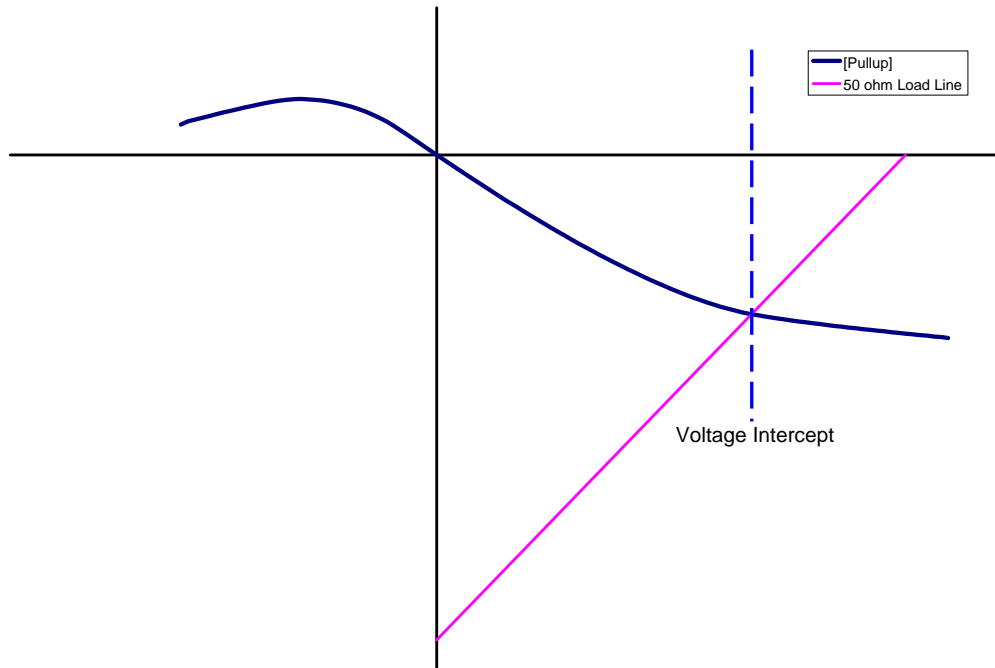

Figure 5.12 – [Pullup] I-V Table Data with Load Line Intercept

In this way, we can see that the conditions, loading and output data for both our I-V and V-T are matched to one another. Similar relationships apply to other I-V and V-T tables that may be present in a final IBIS model.

A test of this sort must be conducted when converting any raw simulation data to IBIS format, to ensure that the resulting model will converge properly in system simulation tools.

5.3 Data Limiting

The IBIS version 2.1 through 3.2 specifications limit V-T tables to 100 points or rows of data total, for each corner, for the [Rising Waveform] and [Falling Waveform] keywords. This limit was extended to 1000 points in IBIS version 4.0. Similarly, I-V table tables are also limited to 100 points total, for each corner, for the [Pullup], [Pulldown], [POWER Clamp], and [GND Clamp] keywords.

These limitations mean that some sort of algorithm must be used to select which points from the raw data file are used in the final IBIS model, should the data file contain more than 100 points per corner. Two methods are now in use:

- Points selected using a regular interval
- Points selected using “greatest change” algorithm

The first of these simply selects data points at regular intervals over the raw data set. For example, in a V-T table data set containing 200 points, from 0 ns to 199 ns, the limitation could be met by selecting only even data points plus zero; the sequence would then be 0 ns, 2 ns, and so on.

While this method is simple to implement, it does not discriminate between “meaningful” and “meaningless” data points. If a V-T table has settled by the 50th used data point, the remaining data points will still be selected and added to the IBIS file, though the voltage information will not change.

This is remedied by use of a “greatest change” algorithm, where each data point is added to the final IBIS table based on the degree of difference between it and surrounding points. In this way, more points in the final IBIS file will be expended on areas of the tables where large changes take place, such as inflections. Few points will be used on areas where the output does not change, such as the settled voltages before and after a V-T transition.

An example is shown in Figure 5.13 below. Note that “flat” or unchanging areas of the graph use few points, while curves and other rapidly changing features are represented with more points.

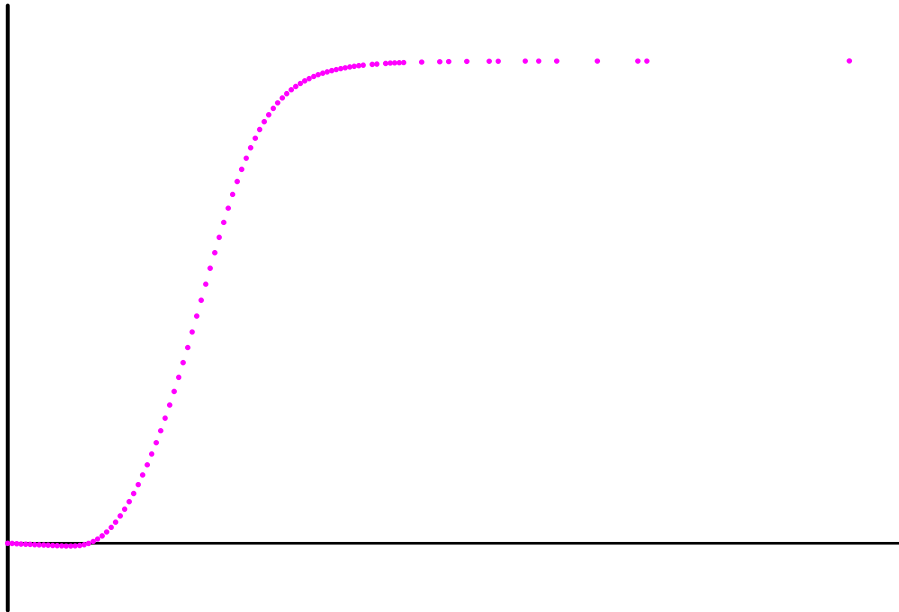

Figure 5.13 – Data Point Selection Example

Note that the point-count restriction applies to the number of x-axis (voltage or time) points in the I-V and V-T tables. Not all I-V current points or V-T voltage points need to be used in the tables, but each table must contain at least two data rows. If necessary, the keyword “NA” may be inserted in the I-V tables for points in any of the corners. The only restrictions on the use of “NA” are:

- the starting and ending points for the typical corner in the V-T and I-V tables cannot use the “NA” reserved word
- if any data is present in the minimum or maximum columns, the first and last points cannot use the “NA” reserved word

This last restriction permits models consisting of typical-only data, where the minimum and maximum corners contain only “NA”.

5.4 Additional Recommendations

Several additional procedures should be followed for V-T and I-V table data processing under certain circumstances. These include:

- Adjustment of data for internal terminations
- Selection of optimum V-T table windows

5.4.1 Internal Terminations

Internal parallel terminations can affect all four I-V tables of a bidirectional (I/O) buffer model. Most commonly, these terminations are implemented through the use of extra on-die structures which act as resistors, always connected to Vcc and/or ground regardless of whether the buffer drives or receives.

Since the clamp tables are used in an I/O buffer when both driving and receiving, such terminations are best included as part of a clamp table. More specifically, ground terminations should be included with [GND Clamp] data and Vcc terminations with [POWER Clamp] data. This assures that, for example, local ground noise effects will properly affect the [GND Clamp] as opposed to the [POWER Clamp].

For example, if a buffer contains an internal ground-connected termination, IBIS can represent the termination's effects even without a specific driver termination keyword. A simplified representation is shown in Figure 5.14 below

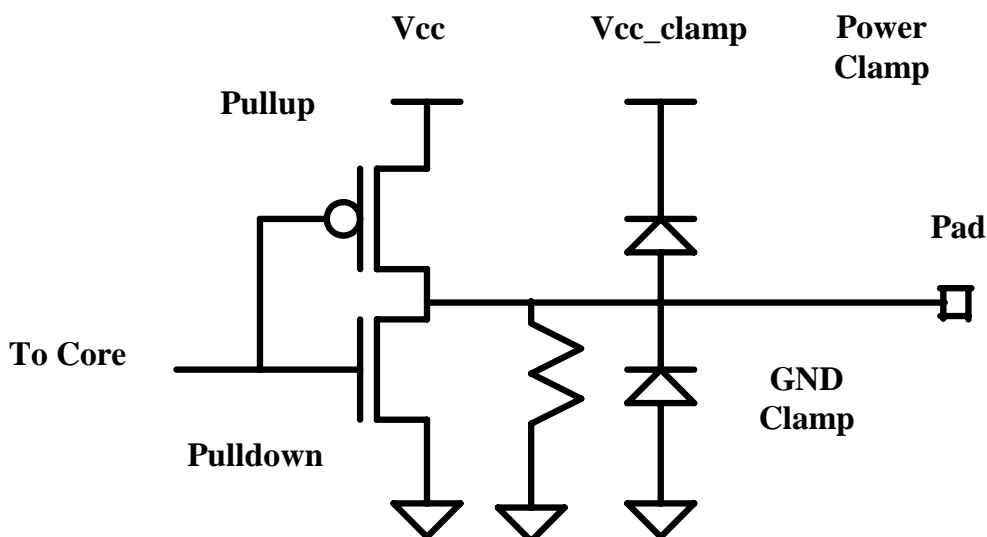

Figure 5.14 – Diagram of I/O Buffer with Internal Termination

Since the clamp measurements include the termination effects and the [Pullup] and [Pulldown] tables will be created by subtracting the clamp data from the raw driving output data, the resistor effects should not appear in these tables and no adjustment to them is necessary. The only change needed to the raw data is to make sure that the resistor's effects are not “double-counted” with the [POWER Clamp] in addition to the [GND Clamp]. The easiest way to accomplish this is by adjusting the power clamp data before it is clipped for inclusion in the IBIS model.

The “raw” I-V data for the high impedance state, swept relative to ground, will look like the following:

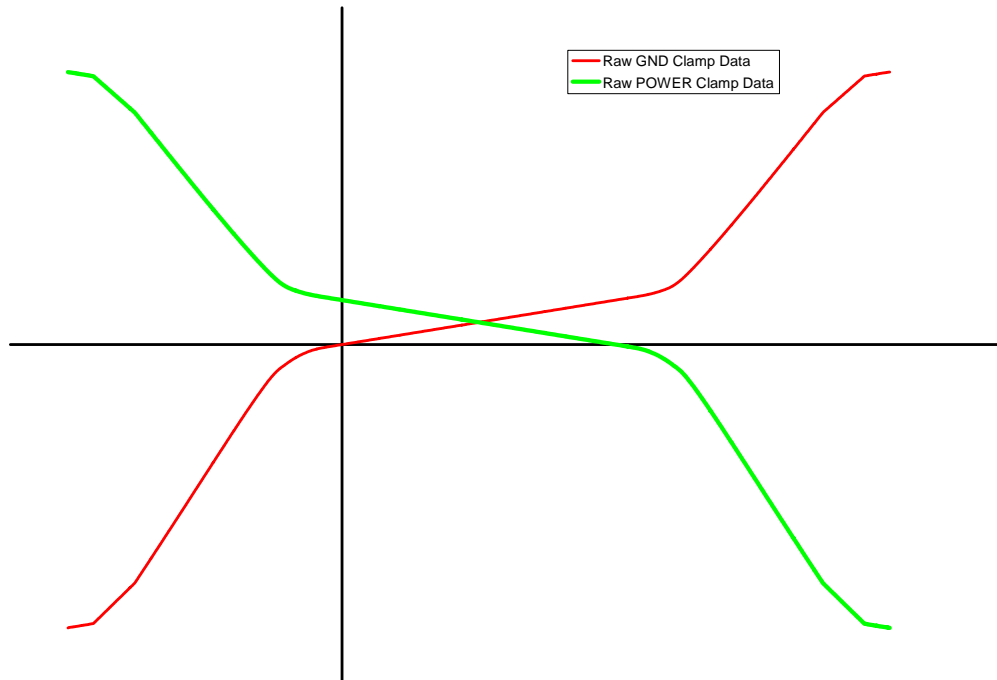

Figure 5.15 – Raw I-V Table Clamp Data for Ground-connected Termination

A recommended procedure for ground clamp adjustment is:

- clip the ground clamp data at V_{cc} (ground-relative)
- extrapolate the ground clamp data at V_{cc} to $2*V_{cc}$
- clip the power clamp data at $0V$ (V_{cc} -relative)
- subtract current from the power clamp data until the current at $0 V$ is $0 A$
- extrapolate the power clamp data at $0 V$ (V_{cc} -relative) to $2*V_{cc}$ (V_{cc} -relative)

Note that this is not the only procedure possible for removing double-counting of termination effects. While it is the most simple, other algorithms may be more appropriate for specific designs.

Figure 5.16 below shows the raw clamp data taken from simulation or the laboratory.

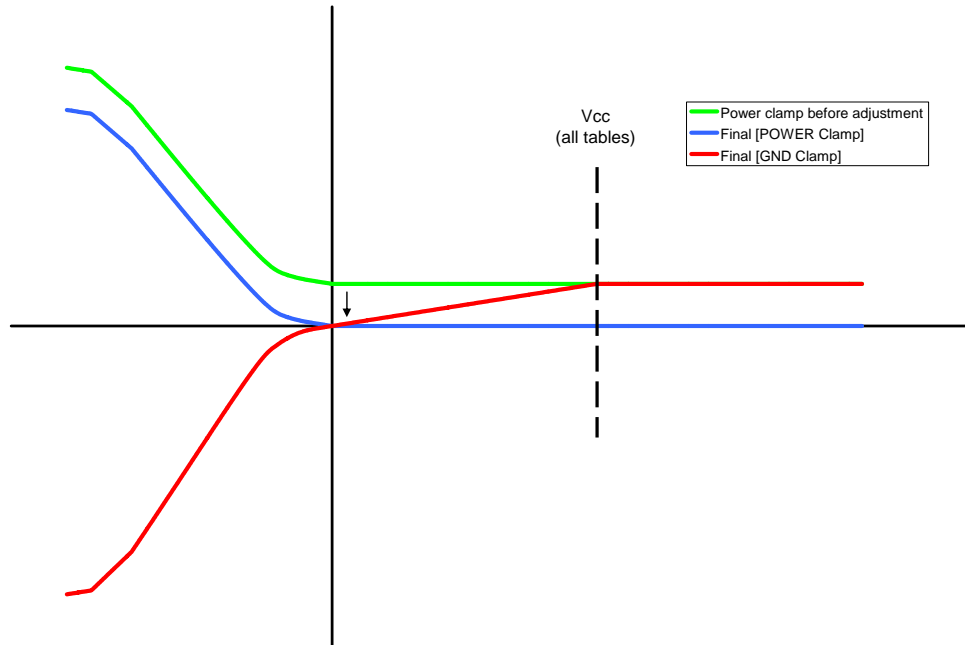

Figure 5.16 – Graph of I-V Data for Ground Terminated Buffer in High-Impedance State

Note that following only the minimum IBIS sweep ranges might result in V_{cc} -connected terminations being included in the [GND Clamp] I-V table of an I/O buffer model. As a result, the procedure for adjusting I-V curves based on V_{cc} -connected terminations is slightly different from that for ground-connected terminations.

As shown in Figure 5.17 below, the ground clamp current flow at 0 V (ground-relative) is negative, implying flow out from the pad.

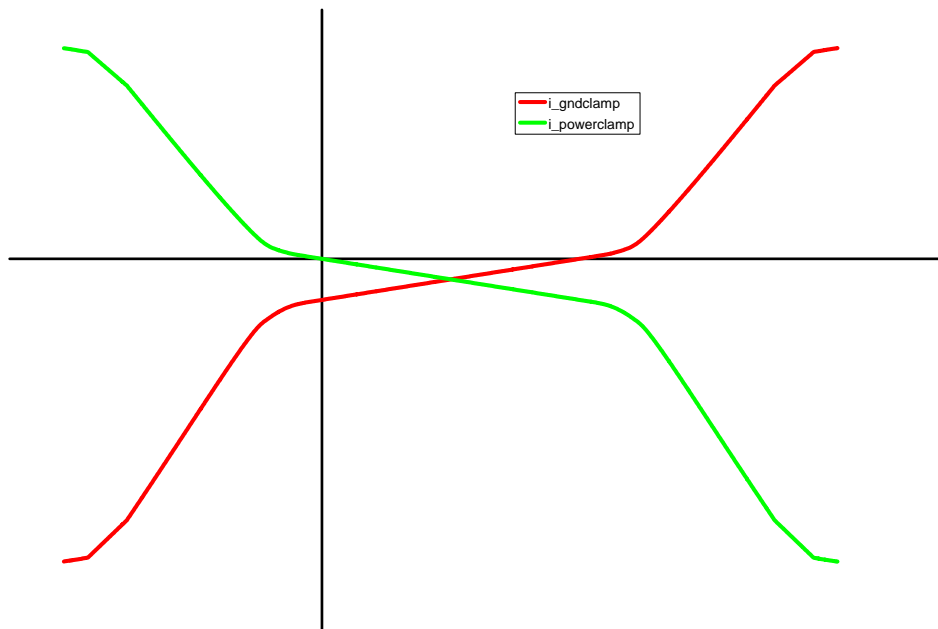

Figure 5.17 – Graph of Power and Ground Clamp I-V Data for V_{cc} -connected Termination

In order to ensure the Vcc-connected termination is represented solely within the power clamp data, the ground clamp must be adjusted in a manner similar to that shown above.

A recommended procedure for Vcc-connected termination adjustment is:

- clip the ground clamp data at 0 V (ground-relative)
- add current until the current at 0 V is 0 A
- extrapolate the ground clamp data at the origin to 2*Vcc
- clip the power clamp data at Vcc (Vcc-relative)
- extrapolate the power clamp data at Vcc (Vcc-relative) to 2*Vcc (Vcc-relative)

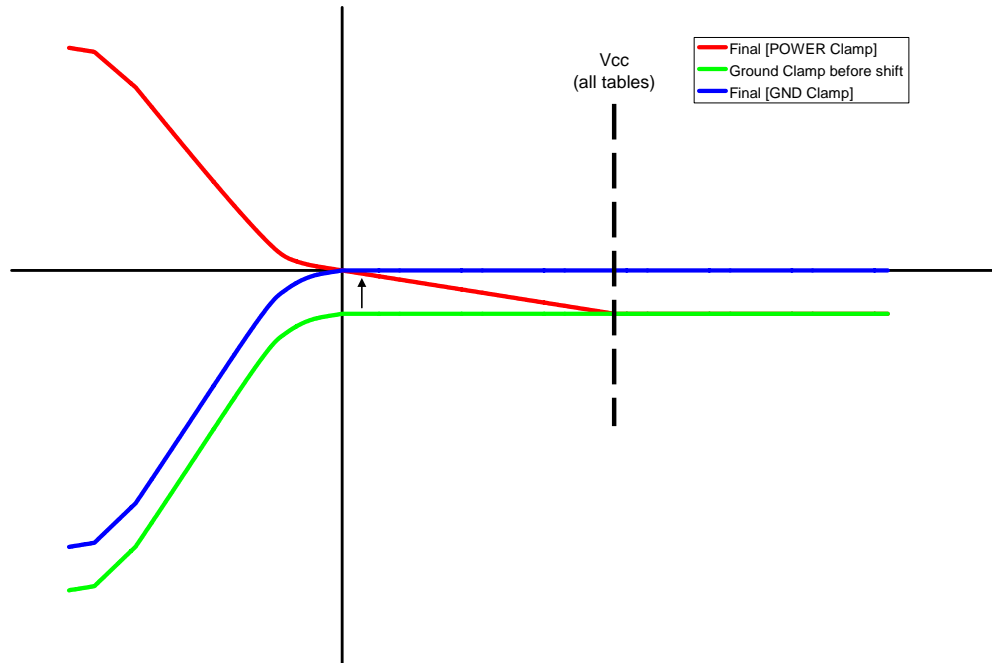

Figure 5.18 – Graph of I-V Data for Vcc Terminated Buffer in High-Impedance State

Other termination types (termination is only on when receiving, only on when driving or receiving specific signal levels, etc.) require advanced keywords, as detailed later in the chapter.

Some designs may feature two parallel terminations: one connecting the pad to ground and another connecting the pad to Vcc. A universal recommendation regarding data collection for and representation of such designs is not possible at this time.

Again, note that this set of procedures for removing double-counting of termination effects is not the only one possible. While it is, the most simple, other algorithms may be more appropriate for specific designs.

5.4.2 V-T Table Windowing

One procedure, which is not performed by most automated IBIS creation tools, is V-T table windowing. While there is no upper limit on the time duration of V-T tables, the transient portion of the waveforms should start and finish within the time dictated by the highest frequency of the buffer (one-half of the period).

While not an IBIS requirement, users are strongly recommended to generate V-T tables that are shorter in duration than the pulse width of the highest frequency anticipated on the interface. For example, a signal that is anticipated to drive, at maximum, 100 MHz signals should have a V-T table duration no greater than 5 ns (the period of a 100 MHz signal is 10 ns; such a signal’s pulse width – longest “high time” or longest “low time” – is 5 ns).

Note that this may limit the types of buffer applications appropriate for modeling under IBIS. Transistor-level models may permit switching of buffer outputs before they have completely finished a transition. However, IBIS version 4.0 assumptions do not cover this situation and buffer response for such a model may be inconsistent across EDA tools implementing IBIS.

5.5 Advanced Keywords and Constructs

Several keywords exist for describing behaviors that are more complex. The most common of these are described below:

- [Model Selector]
- [Submodel]
- [Model Spec]
- [Diff Pin]
- [Driver Schedule]
- [Pin Mapping]
- Series Elements

5.5.1 [Model Selector]

The [Model Selector] keyword is a simple means by which several buffers can be made optionally available for simulation at the same physical pin of the component. Normally, each pin of an IBIS pin list references only one buffer, as shown below.

```

| *****
|
| [Pin]   signal_name  model_name  R_pin  L_pin  C_pin
|
C10      TXD1         EDX_O434
D10      CS           EDX_O395
|
| *****

```

In this example, each pin has a unique pin name and separately references a particular buffer model, found later in the file.

[Model Selector] allows a family of buffers to be “attached” to the same pin. The IBIS specification assumes that the simulation tool using the IBIS file will give the user an option of selection which individual buffer within the family will be selected for use in any particular case.

An extension of this example is shown below.

```

| *****
|
| [Pin]   signal_name   model_name           R_pin  L_pin  C_pin
|
| C10     TXD1          EDX_O43
| D10     CS            EDX_O39
| AA21    FR#           buff_selector_in
| AB23    AM#           buff_selector_out
|
| [Model Selector] buff_selector_out
|
| ADX_O09           1.0V nominal output
| ADX_O0D           1.7V nominal output
|
| [Model Selector] buff_selector_in
|
| XDX_ISS0 1.0V nominal input
| XDX_I550 1.7V nominal input
|
| *****

```

Here, the names of the [Model Selector] families are substituted in the pin list for the buffer names we would usually expect to see. Later in the file, a [Model Selector] keyword is used, followed by the individual buffers that are part of that selector and a short comment or description of that buffer's function. In this example, a user interested in simulating with pin "AA21" would have to select, through his simulation tool, which of the individual buffers under the [Model Selector] "buff_selector_in" he wishes to use in his simulation.

There is little to no restriction on how many buffers or what buffer types can be used in a particular [Model Selector] section.

5.5.2 [Submodel]

The [Submodel] keyword enables additional buffer features under certain conditions. While not the original intent of the keyword, [Submodel] is commonly used to activate additional clamping circuitry when a bi-directional buffer is receiving, but prevent this circuitry from becoming active when the circuit drives. As the [POWER Clamp] and [GND Clamp] data is present during both driving and receiving states, [Submodel] allows extra driving or clamping behaviors to be added only in drive or receive mode.

Imagine an interface with parallel termination at the receiver. The termination is provided by the buffer itself, by leaving the pulldown transistor on when the buffer is receiving; however, the termination is inactive when the buffer drives. By using a dynamic clamp [Submodel] [GND Clamp], the termination can be included in receiving simulations automatically, without affecting the driver behavior.

The Submodel is called by using the [Add Submodel] keyword. The name and mode of operation must be identified under the [Add Submodel] call. Receiver clamps use the "Non-Driving" mode.

```

| *****
| [Add Submodel]
| Submodel name           Mode
| 1550nom                  Non-Driving
| *****

```

The [Submodel] is created by copying the IBIS [Pulldown] table data exactly and relabeling it as a [GND Clamp]. The [Submodel]’s name must be included here and must match the [Add Submodel] call. Finally, the Submodel_type must be specified; as the termination is a clamp that is active only when the buffer receives, the type is “Dynamic_clamp.”

```

| *****
|
| [Submodel]          nom
| Submodel_type      Dynamic_clamp
| [GND Clamp]
|
| Voltage            I(typ)            I(min)            I(max)
|
| 1.50000000E+0      -10.85428894E-3      -10.25383174E-3      -11.60286367E-3
| 1.45000005E+0      -10.75974107E-3      -10.19728184E-3      -11.48986816E-3
| 1.39999998E+0      -10.66339016E-3      -10.14894247E-3      -11.37721539E-3
| ...
| 2.79999995E+0      34.59529579E-3       37.59065270E-3       31.39221668E-3
| 2.84999990E+0      34.65744853E-3       37.69817948E-3       31.43185377E-3
| 2.90000010E+0      34.71648693E-3       37.79786825E-3       31.47053719E-3
|
| *****

```

5.5.3 [Model Spec]

The IBIS specification permits users to describe high and low input thresholds, buffer delay fixtures and delay measurement voltages. These values are given under the [Model] keyword, using the Vinh, Vinl, Cref, Vref, Rref and Vmeas parameters, respectively. In some designs, however, the values for these parameters change with corner or supply voltage. The [Model Spec] keyword allows the variations for these parameters to be described under the typical, minimum and maximum column format used elsewhere in the model.

In the example below, Vmeas, Vinh and Vinl levels are specified for each of the three model corners.

```

| *****
| [Model]            standard_buffer
| Model_type        I/O
|
| Vinl = 0.99V
| Vinh = 1.65V
| Cref = 10.000pF
| Rref = 25.00hm
| Vref = 0.000V
|
|          typ            min            max
| C_comp          3.350pF          3.280pF          3.440pF
| [Model Spec]
| Subparameter    typ            min            max
| Vmeas           0.9405          0.8921          0.9890
| Vinh            1.65            1.565           1.735
| Vinl            0.99            0.939           1.041
| [Voltage Range] 3.300V          3.130V          3.470V
| [POWER Clamp Reference] 5.000V          4.750V          5.250V
| [Temperature Range] 25.0            110.0           0.0
| *****

```

5.5.4 [Diff Pin]

The [Diff Pin] keyword is a simple declaration of differential behavior between two pins in the IBIS pin list. Proper use of the keyword does not require additional table generation or calculation by the user; the keyword only affects how the simulation tool using the IBIS model treats the pins named under the [Diff Pin] keyword.

```
*****  
[Diff Pin]   inv_pin   vdiff   tdelay_typ   tdelay_min   tdelay_max  
|  
C20          D20      25mV    NA           NA           NA  
|*****
```

The IBIS section shown above would appear shortly after the pin list in an IBIS file. The keyword requires six parameters: the pin names to be treated differentially (the non-inverted pin is always named first); the differential threshold voltage if the buffer is capable of receiving signals; and three time delays, expressing the launch delays of the inverting pin in relation to the non-inverting pin when the buffer drives (such delays would be visible as skew, jitter and/or varying crossover voltages between the signals).

Only the pin names are required, and these must match the names given in the [Pin] section. All other parameters may use “NA” as a value (note that “NA” is not equivalent to zero). The differential voltage threshold is typically the minimum difference between inverting and non-inverting pin voltages for the state of the differential input to be considered definitively high or low. For example, an active-high buffer with a vdiff of 100 mV will be considered high if the non-inverting pin is at least 100 mV above the inverting pin. The vdiff parameter overrides the Vinh and Vinl parameters in the [Model]s associated with the inverting and non-inverting pins.

5.5.5 [Driver Schedule]

Some applications require that a buffer change its strength or transition speed characteristics at fixed times after input stimulus changes. For example, a buffer may employ a “kicker” or boosted drive strength on its pullup behavior for the first few nanoseconds after a low-to-high transition. Since the buffer effectively has two drive strengths, no single set of I-V and V-T tables can effectively describe its behavior. The [Driver Schedule] keyword enables a buffer model to use or combine the behaviors of several individual models.

The keyword is itself part of a model, usually called the “top-level” model. The parameters of the keyword form a list of the models whose behavior the top-level model schedules (the top-level model is required for the benefit of simulation tools which cannot support the [Driver Schedule] behavior). Each incorporated model can include up to four delay parameters, expressing the delay for pullup and pulldown behavior turning off or on after a rising or falling edge.

```
*****  
|  
[Model]      GTL_example  
Model_type   I/O  
|  
Vinl = 800.00mV  
Vinh = 1.20V  
Vmeas = 1.00V  
Vref = 1.50V
```

```

Rref = 50.00Ohm
Cref = 0.00pF
|
|           typ           min           max
|
C_comp      2.20pF      1.90pF      2.50pF
[Voltage Range] 1.800V    1.650V    1.900V
[Temperature Range] 50.0      100.0      0.0
|
| *****
|[Driver Schedule]
|
| Model_Name    Rise_on_dly    Rise_off_dly    Fall_on_dly    Fall_off_dly
|
| P0_stage      0.0000ns    5.0000ns      NA             NA
| N0_stage      0.0000ns    NA             0.0000ns      NA
| N1_stage      0.3006ns    NA             0.0549ns      NA
| N2_stage      0.5481ns    NA             0.1163ns      NA
|
| *****

```

The above example illustrates how the [Driver Schedule] keyword is incorporated into a top-level model, just after the header. In this model, five separate models are scheduled by the “GTL_example” top-level model; these models are named in the first data column.

The second and third columns describe how the scheduled buffers are to behave after a rising edge on an input stimulus. “Rise_on_dly” specifies when the pullup section of the scheduled buffer turns on after the rising edge, while “Rise_off_dly” describes when the pullup turns off. Similarly, “Fall_on_dly” and “Fall_off_dly” specify how long a delay exists between the pulldown turning off or on after a falling input edge.

More specifically, in the example above, the P0_stage turns its pullup on immediately after a rising input edge is detected. The buffer pullup turns off 5 ns after this rising input edge. After a falling input edge, the pulldown of N2_stage will wait 0.11163 ns before turning on its pulldown section. In this way, strong pullup and pulldown behaviors are created slowly, as the independent buffers turn on or off in stages after input edges.

5.5.5.1 Pre/De-emphasis Modeling Using [Driver Schedule]

Most leading edge, high frequency communication technologies use some kind of loss compensation technique in drivers and/or receivers today. Even though the IBIS specification (up to version 4.0) is somewhat limited in modeling such buffers in general, a significant number of these buffers in use at the time of this writing can still be modeled with IBIS simple keywords with reasonably good accuracy. This section will discuss how a special kind of driver family, commonly known as the pre-emphasis or de-emphasis buffers can be modeled with the [Driver Schedule] keyword.

In order to help the reader to understand how these buffers can be modeled, a short overview of the operation of a two-tap pre-emphasis buffer will be given first. The following figure shows the block diagram of such a buffer.

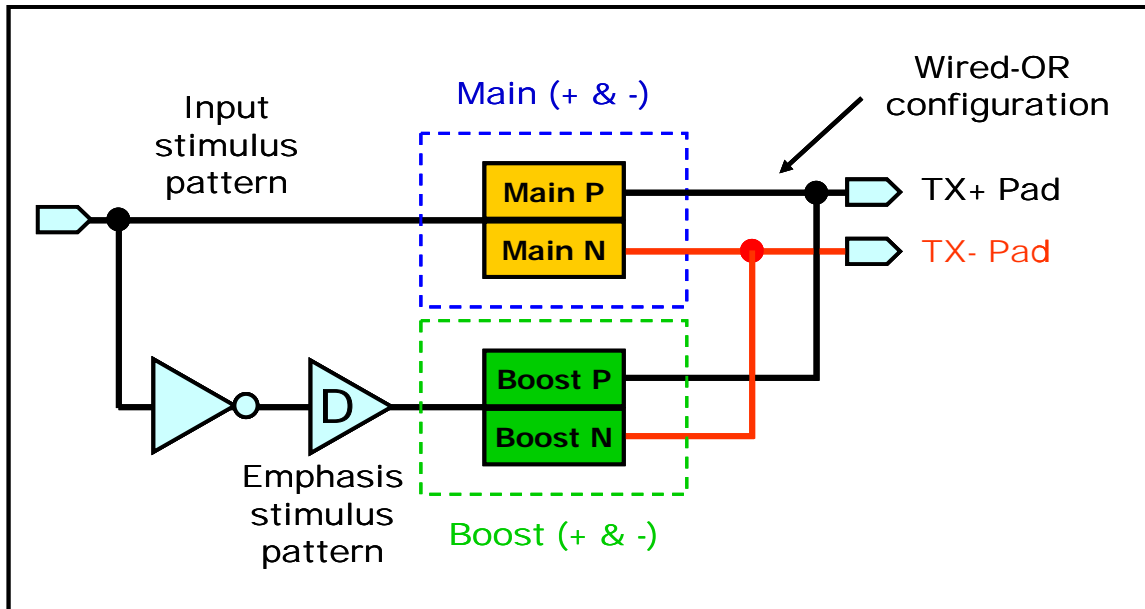

Figure 5.19 - Block Diagram of a Two-Tap Differential Buffer Featuring Pre-Emphasis

A two-tap buffer, as its name implies, consists of two buffer blocks. We will refer to them as the “main” and “boost” buffers in this section. In this particular design, the boost buffer is used to help the main buffer when the new data bit driven onto the bus is different from the previous bit (0 to 1, or 1 to 0 transition). When the data value remains unchanged (repeated bits), the boost buffer is used to weaken the signal strength by driving an inverted version of the data (to oppose the main buffer). This operation can be achieved simply by applying a one bit delayed and inverted stimulus to the input of the boost buffer.

The [Driver Schedule] keyword provides a useful mechanism for turning individual [Model]s, i.e., buffer blocks on or off. Even though the Polarity subparameter of the scheduled [Model]s is overridden by the top-level model (i.e., the scheduled [Model]s cannot have independent polarities), one can still control the polarity of the scheduled [Model]s by choosing the appropriate delay parameters.

For example, constructing an open-drain scheduled buffer using “NA” for the rise_on_dly and fall_on_dly values and zero for the rise_off_dly and fall_off_dly values in the [Driver Schedule] keyword will result in an inverted output, as shown on the waveforms of Figure 5.20 below.

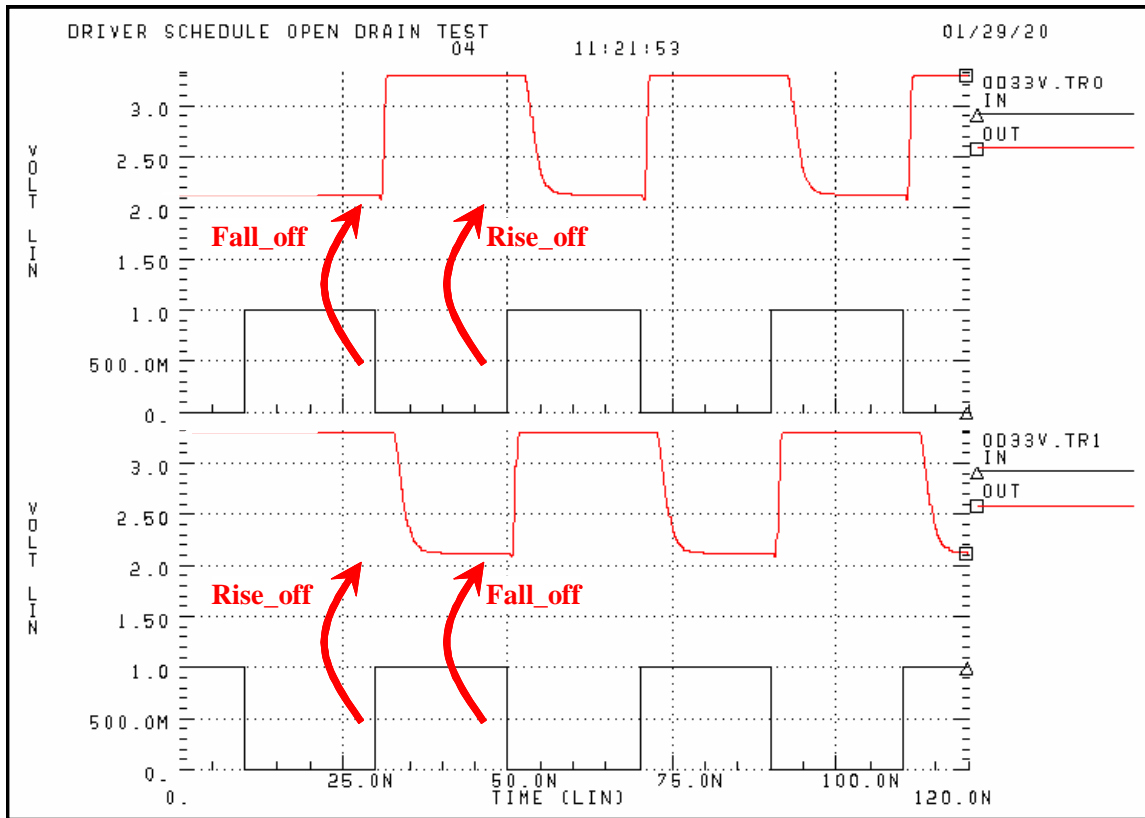

Figure 5.20 – Output of a Scheduled Driver Configured as an Inverter

Using this observation, we are now ready to build a pre-emphasis buffer.

5.5.5.2 Assembling the Pre/De-emphasis Buffer Model

The first step in building a pre-emphasis buffer model is to generate a complete [Model] for its main and boost buffers. In order to achieve this, one must be able to turn off one of these blocks while obtaining the I-V and V-T data for the other. This can be done through enable controls, or by editing the buffer's SPICE circuit. Either method has its advantages and disadvantages.

According to the IBIS specification, only the pullup and/or pulldown I-V tables and their associated V-T tables should be placed in the scheduled [Model]s. The I-V tables of the clamps and C_comp must be placed into the top-level [Model] (see the IBIS specification for more details). Since many of these pre-emphasis buffers also include on-die terminations, care should be taken to avoid duplication of data. Both [Model]'s (main and boost) pullup and/or pulldown I-V tables should contain the difference data (pullup-clamp, and/or pulldown-clamp, where the clamp includes the terminator's currents). The clamp tables in the top-level model should represent the total clamping (and termination) characteristics of the entire buffer. If the clamp I-V tables were generated separately for the main and boost buffers with the SPICE circuit separated, then they will have to be summed together before putting them into the top-level [Model]. If they were generated with a complete buffer circuit using enable controls to place the buffer in a high-impedance state, then one measurement will include the total clamping (and termination) characteristics of the buffer.

Once the I-V and V-T tables are done for the top-level and scheduled [Model]s, we need to add a [Driver Schedule] keyword to the top-level [Model]. This keyword should have two lines, one using the main buffer's

[Model] name and the other using the boost buffer's [Model] name. The main buffer's model should have zero delay values for the `rise_on_dly` and `fall_on_dly` parameters, and "NA" for the `rise_off_dly` and `fall_off_dly` parameters. This ensures that the main buffer's [Model] operates in sync with its input stimulus. The delay values for the boost buffer should contain an "NA" for the `rise_on_dly` and `fall_on_dly` parameters and a number corresponding to the bit width (clock period) for the `rise_off_dly` and `fall_off_dly` parameters.

For example, a buffer model that implements this kind of pre-emphasis (one-bit delay and inversion) using a bit width of 400 ps would have a [Driver Schedule] entry resembling the following:

```

| *****
|
| [Driver Schedule]
|
| Model_Name      Rise_on_dly      Rise_off_dly      Fall_on_dly      Fall_off_dly
|
| main            0.0000ns          NA                0.0000ns          NA
| boost           NA                0.4000ns          NA                0.4000ns
|
| *****

```

Note that this buffer contains a "main" model which features [Pullup] and clamp I-V tables but no [Pulldown] table and only two V-T tables – [Rising Waveform] and [Falling Waveform] – driving into a grounded resistive load. Similarly, the "boost" model features only a [Pullup] I-V table and two associated V-T tables driving into a grounded resistive load.

In reality, the types of delays used for pre-emphasis are most often controlled by the clock input of the buffer. However, since models written with IBIS version 4.0 or older cannot have any explicit clock inputs, the delay parameter of the boost buffer is hard-coded into the model. This means that the user of the IBIS model will have to manually change the delay parameters if the clock frequency of the simulation is different from the clock frequency for which the model was made. Additionally, this may prevent the user of these models to simulate some higher order effects related to clock jitter.

Please note that these concepts may be extended to buffers with more than just two taps. On the other hand, it may not be possible to apply these concepts to each two-tap buffer designs. In order to decide which buffer can be modeled this way one must have a good understanding of the buffer design as well as the capabilities and limitations of the IBIS specification.

5.5.6 [Pin Mapping]

The [Pin Mapping] keyword contains information on how power supplies are connected to individual buffers or groups of buffers. The [Pin Mapping] format generally resembles the [Pin] format, in that all of the component's pins are listed by pin name. Each pin name is followed by entries that associate model supplies with particular names.

As an example, note the following component:

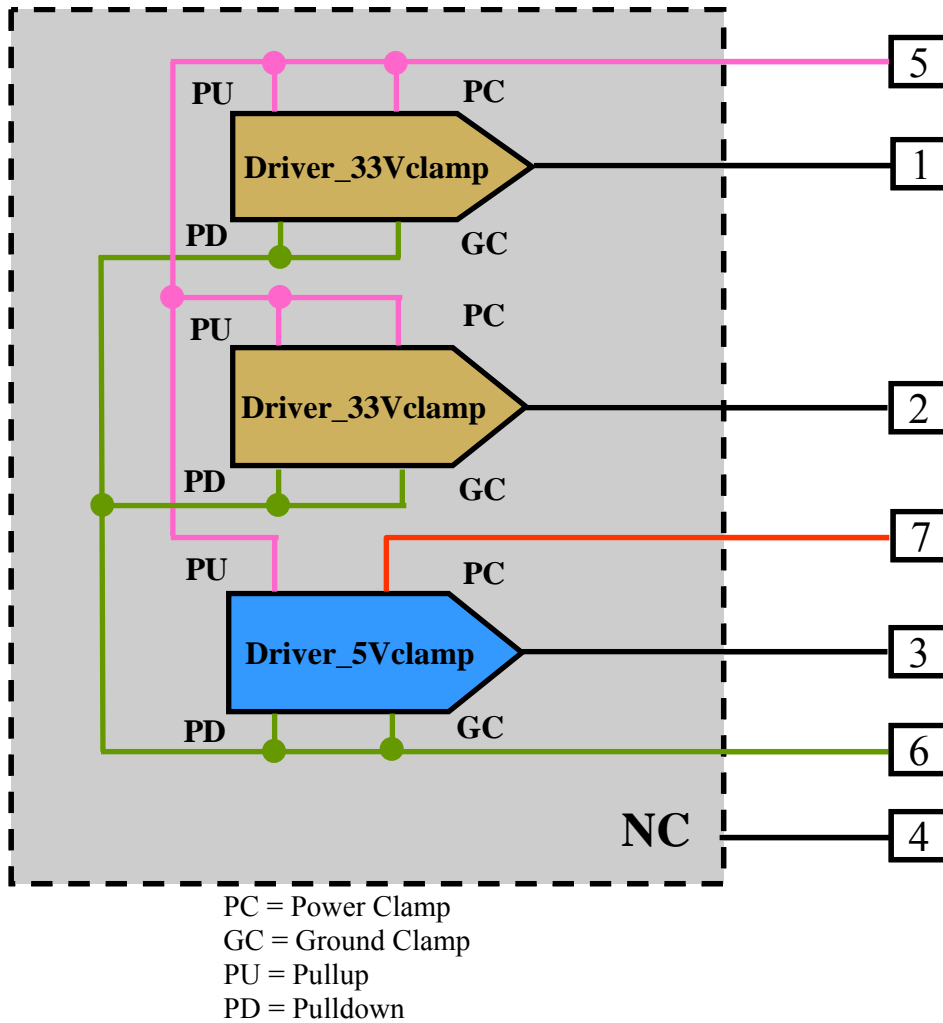

Figure 5.21 – Component Diagram Showing Buffer and Supply Buses

A pin list for this component would resemble the following:

```

| *****
[Pin]  signal_name      model_name  R_pin  L_pin  C_pin
1      Driver_33Vclamp1  iobuffer33
2      Driver_33Vclamp2  iobuffer33
3      Driver_5Vclamp    iobuffer5
4      NC                NC
5      VCC3RAIL          POWER
6      VSSRAIL           GND
7      VCC5RAIL          POWER
|
| *****

```

This component includes three drivers that share the same ground supply and use 3.3 V supplies for their pullups, but have different power clamp supplies. [Pin Mapping] can make these relationships explicit.

```

| *****
[Pin Mapping] pulldown_ref pullup_ref  gnd_clamp_ref  power_clamp_ref  ext_ref
1              VSS          VCC3          VSS             VCC3
2              VSS          VCC3          VSS             VCC3
3              VSS          VCC3          VSS             VCC5
4              NC           NC
| Supply connections only use pullup, pulldown and ext_ref columns
|
5              NC           VCC3          | 3.3 V supply pin
6              VSS          NC            | Ground pin
7              NC           VCC5          | 5.0 V supply pin
|
| *****

```

The first three rows of the [Pin] list above refer to buffers. These I/O buffers have pullup, pulldown, power clamp and ground clamp supply connections. For each buffer pin, the pulldown_ref, pullup_ref, gnd_clamp_ref and power_clamp_ref columns contain the names of rails or buses that connect to the appropriate portions of the buffer.

For example, pin 1 is associated with “Driver_33Vclamp1” which uses the model “iobuffer33.” The pullup of this buffer is connected to the supply rail named “VCC3”, as shown the pullup_ref column for pin 1 of the [Pin Mapping] keyword. Similarly, the buffer “Driver_5Vclamp” has a power clamp that is connected to the supply rail named “VCC5.”

POWER and GND pins are not associated with buffers but are instead the points at which supply buses connect to the pins of the component. In other words, POWER and GND pins in the [Pin] list are assumed to provide supply voltages to the [Pin Mapping] buses and therefore to the component’s buffers. Under the [Pin Mapping] keyword, entries for POWER and GND pins are only to be placed in the second, third (and possibly sixth column). The pulldown_ref column contains the name of the bus to which the GND pin is connected; for GND pins, the pullup_ref column must contain NC. Similarly, the pullup_ref column contains the name of the bus to which the POWER pin is connected; for POWER pins, the pulldown_ref column must contain NC.

For POWER and GND pins, the sixth column, ext_ref, may contain a bus name, to refer to an external reference voltage. If ext_ref contains an entry, the gnd_clamp_ref and power_clamp_ref columns must contain NC.

In the example above, pin 5, a POWER pin in the [Pin] list, carries the VCC3 3.3 V supply voltage. Similarly, pin 7, also a POWER pin, carries the VCC5 5.0 V supply voltage. The ground pin for all buffers is pin 6, a GND pin.

Note that all buses must connect to either a POWER or GND pin. However, buses may be defined without any buffer connections. The IBIS specification requires that, if [Pin Mapping] is present, EVERY pin from the [Pin] list must be also listed under [Pin Mapping].

The [Pin Mapping] keyword does not directly affect or alter package model information given elsewhere in the model. The bus connections described by [Pin Mapping] are assumed as ideal shorts, but do not override parasitic information given for power and/or ground pins.

5.5.7 Series Elements

Series elements and other electrical connections between pads may be described using combinations of the keywords [Series Current], [Series MOSFET], [Series Pin Mapping], [Series Switch Groups] and several others. Series connections may be made between pads to which single-ended buffers are already connected (see Figure 5.22 below). Also, note that the use of any of these keywords does not demand or preclude the use of the [Diff Pin] keyword.

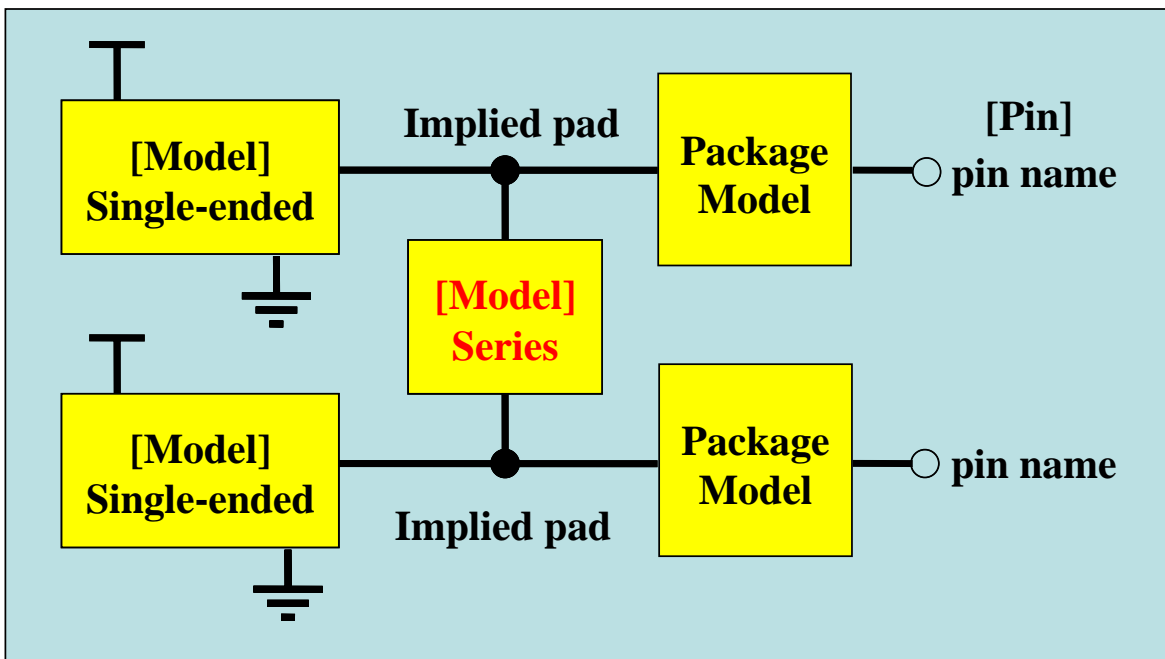

Figure 5.22 – Connection of Single-ended and Series [Model]s

Proper declaration of non-switch series elements involves at least two steps:

- use of [Series Pin Mapping] to declare the connection (this keyword is usually placed between [Pin] and the first [Model] keyword)
- use of a [Model] of Model_type “Series” which includes one or more of the following keywords and data sets: [Series Current], [Series MOSFET], [R Series], [L Series], [C Series], [Rl Series], [Rc Series], [Lc Series]

Proper declaration of series switch elements involves a more complicated procedure:

- use of [Series Pin Mapping] to declare the connection (this keyword is usually placed between [Pin] and the first [Model] keyword)
- use of [Series Switch Groups] to declare the grouping of enabled states of the switch

- use of a [Model], of Model_type “Series_switch,” which includes the [On] and [Off] keywords each of which contain one or more of the following keywords and data sets: [Series Current], [Series MOSFET], [R Series], [L Series], [C Series], [RI Series], [Rc Series], [Lc Series]

For example, an IBIS file that models an RC circuit that connects two pins of a component would resemble, in part, the following:

```

| *****
[IBIS Ver]    3.2
[File Name]  rcpath-test.ibs
[File Rev]   1.0
[Date]       8/22/2003
[Source]     From silicon level SPICE model.
[Notes]      The following information is for illustration purposes only
              and does not conform to any known device.
[Disclaimer] See above.
[Copyright]  Copyright (C) 2005 The IBIS Open Forum
|
| *****
[Component]  Example_RCseries
[Manufacturer] None
[Package]
|
|          typ      min      max
R_pkg      0.00hm   0.00hm   0.00hm
L_pkg      0.00H    0.00H    0.00H
C_pkg      0.00F    0.00F    0.00F
|
| *****
[Pin]  signal_name  model_name  R_pin  L_pin  C_pin
1      RC_test     Groundclamp
2      RC_test     Groundclamp
|
| *****
[Series Pin Mapping]  pin_2  model_name  function_table_group
1                    2      RCpath
|
| *****
[Model]      Groundclamp
Model_type   Input
Polarity     Non-Inverting
Vinh = 2.0
Vinl = 0.8
|
|          typ      min      max
C_comp      7.0pF    5.0pF    9.0pF
|
|          typ      min      max
[Voltage Range]  5.0V    4.5V    5.5V
|
[GND Clamp]
|
|          Voltage          I(typ)          I(min)          I(max)
1.50000000E+0    -10.85428894E-3    -10.25383174E-3    -11.60286367E-3
1.45000005E+0    -10.75974107E-3    -10.19728184E-3    -11.48986816E-3

```

```

1.39999998E+0    -10.66339016E-3    -10.14894247E-3    -11.37721539E-3
|
2.79999995E+0     34.59529579E-3     37.59065270E-3     31.39221668E-3
2.84999990E+0     34.65744853E-3     37.69817948E-3     31.43185377E-3
2.90000010E+0     34.71648693E-3     37.79786825E-3     31.47053719E-3
|
*****
[Model]          RCpath
Model_type       Series
Polarity         Non-Inverting
Enable          Active-High
|
|              typ      min      max
C_comp          0.0pF    0.0pF    0.0pF
|
|              typ      min      max
[Voltage Range] 5.0V    4.5V    5.5V
|
*****
|              R(typ)  R(min) R(max)
[Rc Series]     4ohm    NA     NA
|
|              C(typ)  C(min) C(max)
[C Series]     50pF    NA     NA
|
[End]

```

In the example above, electrical information is given both for the single-ended behavior of the component's two pins and for the RC circuit between the pins. The [Rc Series] keyword describes the resistance assumed to exist in series with the capacitance defined by the [C Series] keyword.

Similarly, an IBIS file which models a MOSFET with source and drain connecting two pins of a component would resemble, in part, the following:

```

*****
[IBIS Ver]      3.2
[File Name]     mosfet-test.ibs
[File Rev]      1.0
[Date]          8/22/2003
[Source]        From silicon level SPICE model.
[Notes]         The following information is for illustration purposes only
                and does not conform to any known device.
[Disclaimer]    See above.
[Copyright]     Copyright (C) 2005 The IBIS Open Forum
|
*****
[Component]     Example_Switch
[Manufacturer]  None
[Package]
|              typ      min      max
R_pkg          0.00Ohm  0.00Ohm  0.00Ohm
L_pkg          0.00H    0.00H    0.00H
C_pkg          0.00F    0.00F    0.00F
|
*****

```

```

[Pin]   signal_name  model_name  R_pin  L_pin  C_pin
1       MOSFET_test NC
2       MOSFET_test NC
|
| *****
[Series Pin Mapping]  pin_2  model_name  function_table_group
1                    2      mosfet          1
|
| *****
[Series Switch Groups]
On  1  /
Off 1  /
|
| *****
[Model]           mosfet
Model_type        Series_switch
Polarity          Non-Inverting
Enable            Active-High
|
|           typ  min  max
C_comp  7.0pF  5.0pF  9.0pF
|
|           variable  typ  min  max
[Voltage Range]  5.0V  4.5V  5.5V
|
| *****
[On]
[Series MOSFET]
Vds = 5
| Voltage I(typ)      I(min)          I(max)
5.0V      6.4475      3.8325          9.9875      | Defines the Ids current as a
4.0V      5.075       2.985           7.9325      | function of Vtable for Vds = 5
3.0V      3.245       1.8675          5.14
2.0V      0.78        0.415           1.275
1.0V      1.31E-09    1.1675E-09      1.4175E-09
0.0V      0           0                0
|
[Series MOSFET]
Vds = 3
| Voltage I(typ)      I(min)          I(max)
5.0V      2.3211      1.3797          3.5955      | Defines the Ids current as a
4.0V      1.827       1.0746          2.8557      | function of Vtable for Vds = 3
3.0V      1.1682      0.6723          1.8504
2.0V      0.2808      0.1494          0.459
1.0V      4.743E-10    4.203E-10       5.103E-10
0.0V      0           0                0
|
[Series MOSFET]
Vds = 1
| Voltage I(typ)      I(min)          I(max)
5.0V      2.58E-01      1.53E-01        4.00E-01    | Defines the Ids current as a
4.0V      2.03E-01      1.19E-01        3.17E-01    | function of Vtable for Vds = 1
3.0V      1.30E-01      7.47E-02        2.06E-01
2.0V      3.12E-02      1.66E-02        5.10E-02
1.0V      5.27E-11      4.67E-11        5.67E-11
0.0V      0           0                0

```

```

|
[Off]
[Series Current]
| Voltage I(typ)      I(min)      I(max)
5.0V      0          0          0
4.0V      0          0          0
3.0V      0          0          0
2.0V      0          0          0
1.0V      0          0          0
0.0V      0          0          0
|
[End]

```

Note that, in the example above, no single-ended models exist for the two pins of the component. The only electrical behavior described is that between the pins. The specification permits the use of terminators, inputs or other types of single-ended buffers on these pins, however.

Additionally, note that several [Series MOSFET] keywords exist under the [On] keyword, to describe the current seen at different Vds values. Finally, observe that the [Off] keyword uses the [Series Current] keyword, rather than [Series MOSFET], to describe a current that does not depend on a particular Vds value. The specification also permits the use of [Series MOSFET] for buffers of type Series, instead of type Series_switch. In this case, the [On] and [Off] keywords are not required.

The IBIS specification also permits the use of [Series Current] and [Rc Series], [C Series], etc. series element keywords within the scope of the same [Model] keyword. This may be appropriate for descriptions of DC and frequency dependent behavior for the same series [Model].

Finally, the [Series MOSFET] keyword is only intended to include data describing the state of the buffer (on, off) and the current relationship between source and drain as a function of source-drain voltage. [Series MOSFET] does not include any gate information. Switching or control of the buffer changing state is not captured by the keyword.

5.5.8 [Test Data] and Reference Waveforms

In addition to the recommended V-T tables, more switching waveforms may be included for simulator validation purposes. These waveforms act as a reference for comparison against specific simulation outputs, not raw V-T data that the simulator uses to construct the behavioral model. This is particularly useful for correlating complex buffer models such as those using [Driver Schedule], where no single V-T table may represent the switching behavior of the entire buffer.

Unlike the recommend V-T table loads above, the load circuits used to generate waveforms can include reactive elements and even transmission lines. Two popular reference waveform loads are 50 ohms to $(V_{cc} - GND) / 2$, and a 50 pF load to ground. The model maker may also wish to include a waveform of the buffer driving a load that represents the typical load found in the buffer's intended application. [Test Data] and associated keywords and subparameters, such as [Test Load], can be used to include any number of reference waveforms in an IBIS file.

6.0 Validating the Model

Once an IBIS model has been created, it must be validated. Validation involves:

1. Checking the model using IBISCHK4
2. Running the model with standard loads
3. Comparing the results against a transistor-level reference simulation using the same loads

The IBISCHK4 parser is a computer program provided by the IBIS Open Forum to check the syntax of IBIS models. IBISCHK4 is free of charge and can be obtained through the Open Forum website (see ***Error! Reference source not found.*** below). The parser also provides some basic checks of data, such as matching between I-V and V-T tables, monotonicity of table data and the like. While running the parser is essential to checking the validity of IBIS model data, its checks are not exhaustive and should not be seen as sufficient to guarantee a good model.

For model validation in a system environment, you can use any simulator that supports IBIS. Contact the simulator vendor and request their parser, converter, or application note on using IBIS models on their tools. To find simulator vendors that support IBIS, see the IBIS member organization list maintained on the IBIS web site (see ***Error! Reference source not found.*** below).

7.0 Correlating the Data

The last step in the modeling process is to correlate the simulation results with actual silicon measurements. To obtain I-V tables and rise/fall time measurements, see the section titled *Obtaining I-V and Switching Information via Lab Measurement*.

Correlation involves measuring the I-V tables and transient response (V-T tables or ramps) of an actual device and verifying that they fall within the maximum and minimum values used in the IBIS model. In addition, for integrated circuits in a motherboard or other test environment driving a known load, compare the oscilloscope waveforms with simulation waveforms using the same load.

Note

The oscilloscope adds a load to the circuit and the response of the oscilloscope affects the response measured.

A detailed set of recommendations for improving IBIS model accuracy can be found in the IBIS Accuracy Report:

<http://www.eda.org/ibis/accuracy/>

A procedure for helping to optimize IBIS model quality can be found in the IBIS Quality Checklist, from the IBIS Quality Subcommittee:

<http://www.sissoft.com/ibis-quality/>.

8.0 Resources

The IBIS Open Forum is a committee of the GEIA (Government Electronics and Information Technology Association), part of the Electronics Industries Association. As such, the IBIS Open Forum is responsible for the official IBIS specification. Minutes of IBIS meetings, email correspondence, proposals for specification changes, etc. are online at “eda.org”. To join in the email discussions, send a message to “ibis-request@eda.org” and request that your name be added to the IBIS administrative and/or users’ mail reflectors. Be sure to include your email address.

To download a copy of the specification, the IBISCHK4 parser, various public-domain models, S2IBIS3 and other information, visit the IBIS Web page:

<http://www.eigroup.org/ibis/>

A significant amount of information is available through the IBIS Open Forum’s website:

<http://www.eda.org/ibis/>

Of particular interest is the archive of materials presented at the regular IBIS Summits sponsored by the Open Forum. Topics include IBIS performance at multi-gigahertz speeds, advanced modeling techniques and power delivery simulation using IBIS. The archive indices are available at:

<http://www.eda.org/ibis/summits/>